

TSF CONNECTOR

2.5mm pitch/Disconnectable Crimp style connectors

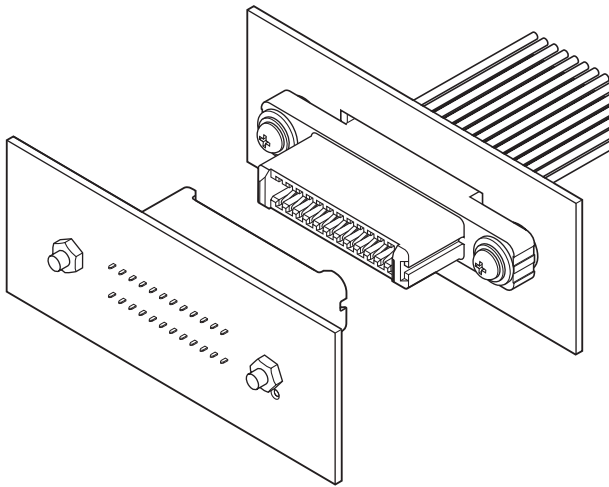

This TSF connector is a drawer connector with floating function which makes design of equipment easy.

Putting the phase lag on four grounding contacts at both ends and other contacts of signal and power supply, the sequential connecting is realized.

- Floating function
- Sequential mechanism
- Stabilized contact performance by adopting the bellows type contact
- Wide usable fixation method (Standard M3 metric screw)

Specifications

- Current rating: 3A AC, DC (AWG #22)
 - Voltage rating: 50V AC, DC
 - Temperature range: -25°C to +85°C
(including temperature rise in applying electrical current)
 - Contact resistance: Initial value/ 30m Ω max.
After environmental testing/ 50m Ω max.
 - Insulation resistance: 1,000M Ω min.
 - Withstanding voltage: 500V AC/minute
 - Applicable wire: Conductor size/AWG #26 to #22
Insulation O.D./ 1.2 to 1.9mm
 - Applicable PC board thickness: 1.6mm
- * Compliant with RoHS.
* Refer to "General Instruction and Notice when using Terminals and Connectors" at the end of this catalog.
* Contact JST for details.

**Panel layout for receptacle
(viewed from component side)**

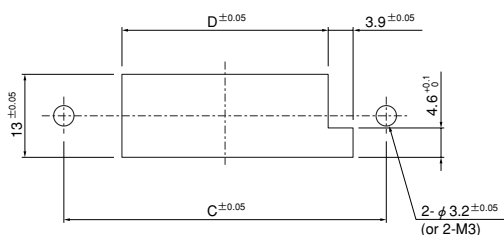

- Note: 1. Punch holes in the panel according to the figures shown above. Burrs must be removed.
2. The strength of the panel must be considered when punching two or more holes.

**PC board layout for plug
(viewed from component side)**

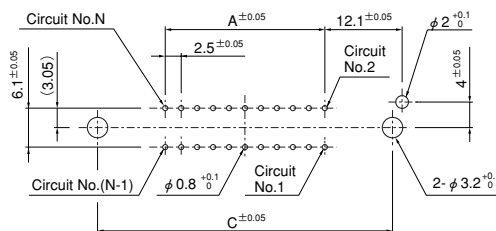

- Note: 1. Tolerances for pattern pitch are non-cumulative: ± 0.05 mm for all centers.
2. Hole dimensions differ according to the type of PC board and piercing method. The dimensions above should serve as a guideline. Contact JST for details.

Assembly layout

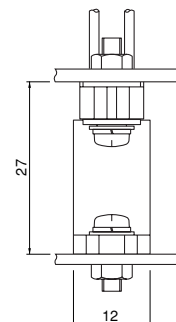

TSF CONNECTOR

Receptacle contact

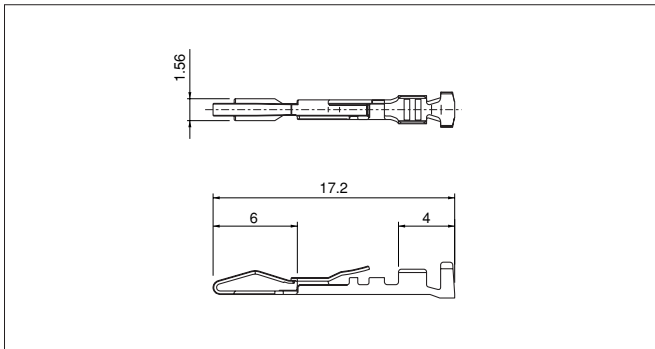

Model No.	Applicable wire		Insulation O.D. (mm)	Q'ty / reel
	mm ²	AWG#		
STSF-001GG-M0.6	0.13~0.33	26~22	φ 1.2~φ 1.9	10,000

Material and Finish

Copper alloy, nickel-undercoated, Mating part: gold-plated

Crimping part: tin-plated (reflow treatment)

RoHS compliance

Contact	Crimping machine	Applicator		
		Crimp applicator	Dies	Crimp applicator with dies
STSF-001GG-M0.6	AP-K2N	MKS-L	MK/STS/D/F001-06	APLMK STS/D/F001-06

Receptacle

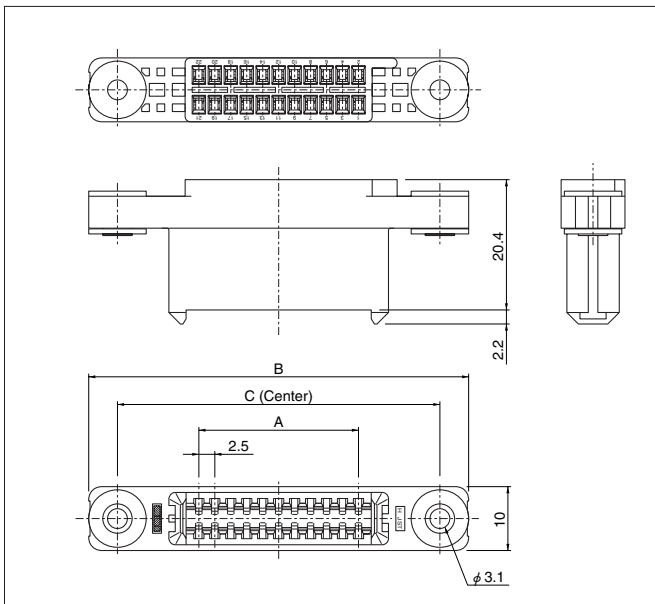

Circuits	Model No.	Dimensions (mm)				Q'ty / box
		A	B	C	D	
14	TSFR-14V-K-FB	15.0	49.5	40.5	22.3	486
16	TSFR-16V-K-FB	17.5	52.0	43.0	24.8	432
18	TSFR-18V-K-FB	20.0	54.5	45.5	27.3	378
20	TSFR-20V-K-FB	22.5	57.0	48.0	29.8	378
24	TSFR-24V-K-FB	27.5	62.0	53.0	34.8	324

Material and Finish

Washer, Floating rivet: Copper alloy, nickel-plated

Housing: Glass-filled PBT, UL94V-0, black

RoHS compliance

Plug

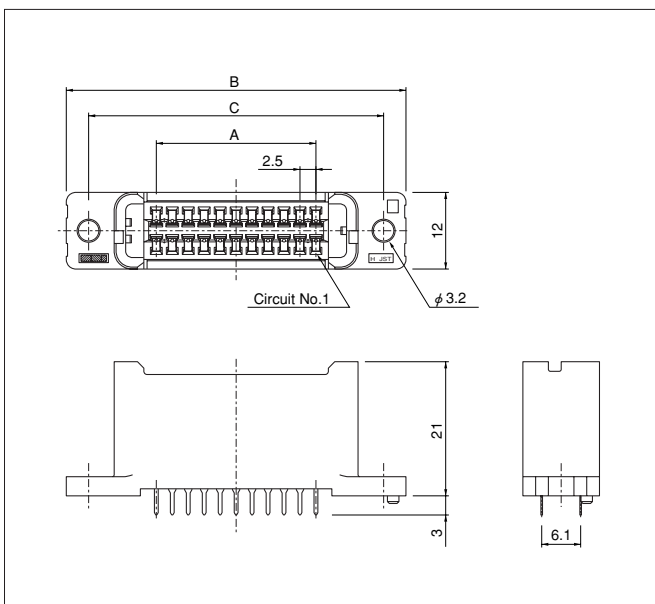

Circuits	Model No.	Dimensions (mm)			Q'ty / box
		A	B	C	
14	TSFP-14V-K5GG	15.0	43.2	36.2	378
16	TSFP-16V-K5GG	17.5	45.7	38.7	378
18	TSFP-18V-K5GG	20.0	48.2	41.2	378
20	TSFP-20V-K5GG	22.5	50.7	43.7	324
24	TSFP-24V-K5GG	27.5	55.7	48.7	324

Material and Finish

Contact: Copper alloy, nickel-undercoated, Mating part: gold-plated

Solder tail: tin-plated (reflow treatment)

Housing: Glass-filled PBT, UL94V-0, black

RoHS compliance