

ASSEMBLY ITEM NUMBER	PART CHARACTERISTICS	
	NUMBER OF POSITION	PANEL MOUNT OPTION
43020-0200	02	YES
43020-0201	02	NO
43020-0400	04	YES
43020-0401	04	NO
43020-0600	06	YES
43020-0601	06	NO
43020-0800	08	YES
43020-0801	08	NO
43020-1000	10	YES
43020-1001	10	NO
43020-1200	12	YES
43020-1201	12	NO
43020-1400	14	YES
43020-1401	14	NO
43020-1600	16	YES
43020-1601	16	NO
43020-1800	18	YES
43020-1801	18	NO
43020-2000	20	YES
43020-2001	20	NO
43020-2200	22	YES
43020-2201	22	NO
43020-2400	24	YES
43020-2401	24	NO

CKT. NO.	DIM. 'A'	DIM. 'B'	DIM. 'C'	DIM. 'D'
2	.152/(3.86)	N/A	.166/(4.21)	.311/(7.90)
4	.270/(6.85)	.118/(3.00)	.284/(7.21)	.429/(10.90)
6	.388/(9.85)	.236/(6.00)	.402/(10.21)	.547/(13.89)
8	.506/(12.85)	.354/(9.00)	.520/(13.21)	.665/(16.89)
10	.624/(15.85)	.472/(12.00)	.638/(16.21)	.783/(19.89)
12	.742/(18.85)	.591/(15.00)	.756/(19.21)	.901/(22.89)
14	.860/(21.85)	.709/(18.00)	.874/(22.20)	1.019/(25.88)
16	.978/(24.85)	.827/(21.00)	.992/(25.20)	1.137/(28.88)
18	1.096/(27.85)	.945/(24.00)	1.110/(28.20)	1.255/(31.88)
20	1.215/(30.85)	1.063/(27.00)	1.229/(31.22)	1.373/(34.87)
22	1.333/(33.85)	1.181/(30.00)	1.347/(34.22)	1.491/(37.87)
24	1.451/(36.85)	1.299/(33.00)	1.465/(37.22)	1.609/(40.87)

- NOTES:
- 1) HOUSING MATERIAL: UNFILLED POLYESTER (PBT), UL 94V-0
COLOR - BLACK
 - 2) FINISH: N/A
 - 3) PRODUCT SPECIFICATION: PS-43045
 - 4) PACKAGING SPECIFICATION: N/A
 - 5) THIS HOUSING MATES WITH MICRO-FIT RECEPTACLE #43025-****
 - 6) THIS HOUSING TO BE USED WITH MOLEX MALE TERMINAL #43031-****
 - 7) DESIGNED FOR .055(1.4) MINIMUM TO A .100(2.54) MAXIMUM THICK PANEL OR PRINTED CIRCUIT BOARD.
 - 8) SEE SECTION 'D'-'D' FOR TERMINAL ORIENTATION IN HOUSING.
 - 9) PANEL MOUNT FEATURES MUST LOCK ON SIDE OPPOSITE PUNCH SIDE FOR OPTIMUM RETENTION.
 - 10) PART CONFORMS TO CLASS 'B' REQUIREMENTS OF COSMETIC SPECIFICATION PS-45499-002. SOME HOUSINGS MAY HAVE A SMALL GATE BLEMISH NEAR THE GATE LOCATION THAT DOES NOT AFFECT FUNCTIONALITY.

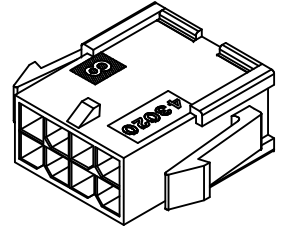
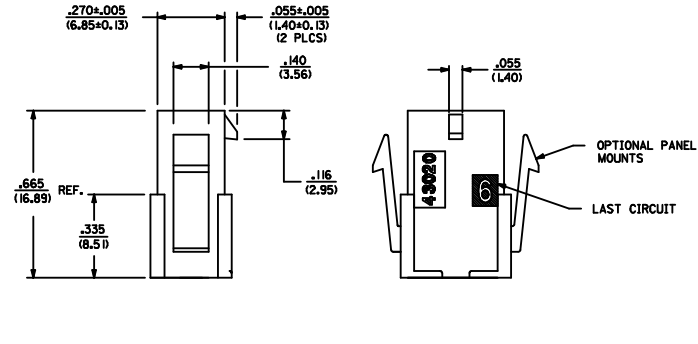
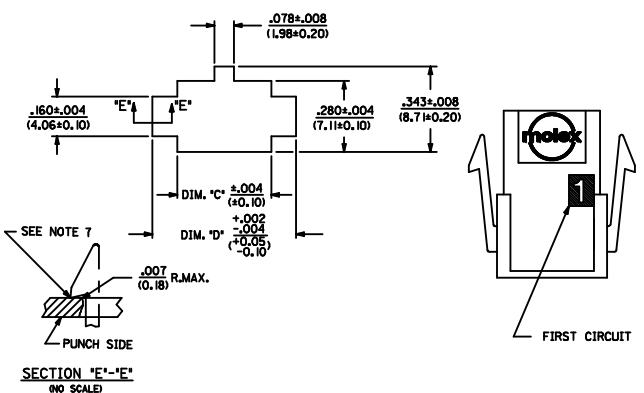
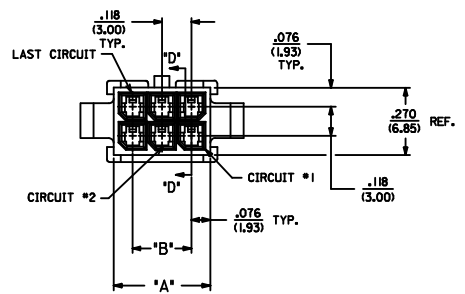

PLUG WITH OPTIONAL PANEL MOUNTS
ISO VIEW
(8 CIRCUIT SHOWN)

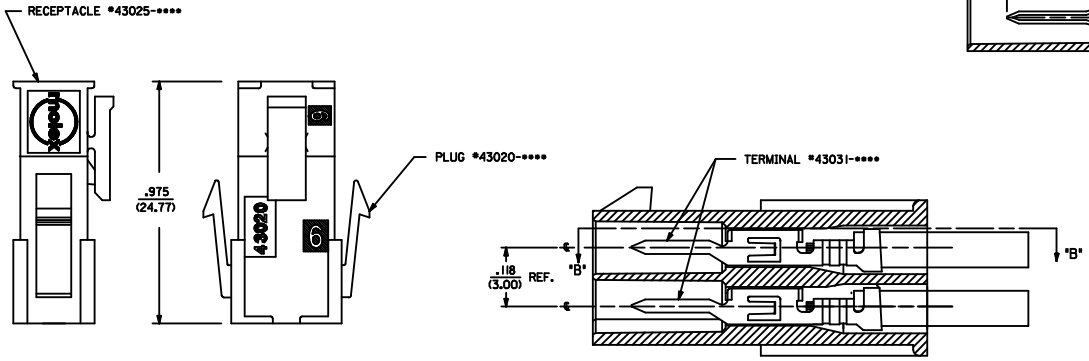
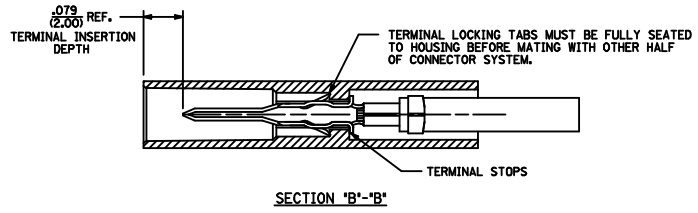

MATED MICRO-FIT CONNECTOR

SECTION 'D'-'D' WITH TERMINAL (SCALE 8X)

COSMETIC SPEC ELEC NO. UCP2009-2841 2/2009/05/26 DRINKS/SOUSEK 2009/05/28 CHYK/CHK/PPER 2009/05/28 APPROV:SMTH	QUALITY SYMBOLS	GENERAL TOLERANCES (UNLESS SPECIFIED)	DIMENSION STYLE	SCALE	DESIGN UNITS	THIRD ANGLE PROJECTION	
	$\nabla=0$ $\nabla=0$	4 PLACES ± --- ± --- 3 PLACES ± --- ± .010 2 PLACES ± 0.25 ± .014 1 PLACE ± 0.35 ± --- ANGULAR ±1/2°	IN/MM INCH	IN/MM DATE	4:1	METRIC	
	DRAFT WHERE APPLICABLE MUST REMAIN WITHIN DIMENSIONS	DRAWN BY: AFG CHECKED BY: BAP APPROVED BY: RAS DATE: 1993/01/07	MATERIAL NO.: SEE CHART DOCUMENT NO.: SDA-43020-****	TITLE: MICRO-FIT(3.0) 2 THRU 24 CIRCUIT PLUG WITH OPTIONAL PANEL MOUNTS MOLEX INCORPORATED			SHEET NO.: 1 OF 1