

GKS 113 M

Screw-in Test Probes

Grid:

≥ 4,0 mm

≥ 160 Mil

Installation height with KS: 10,5 mm (.413)

Recommended stroke: 4,0 mm (.157)

Mounting and functional dimensions

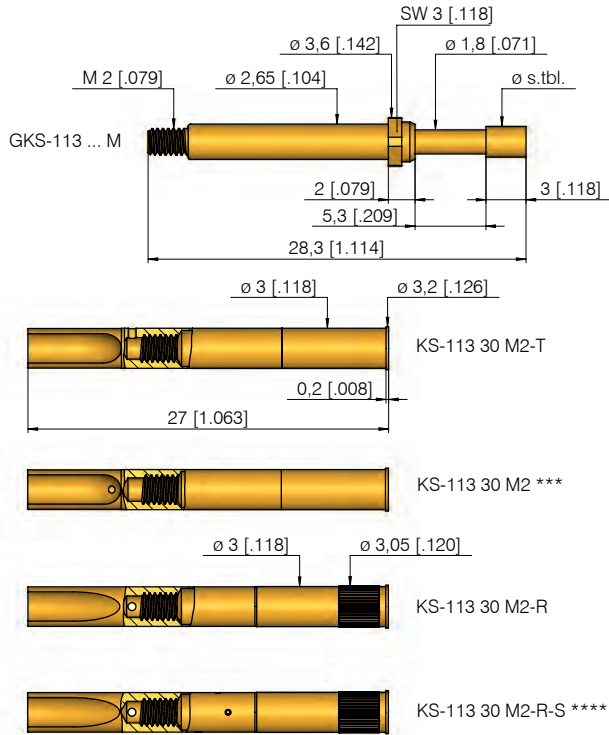

*** axially positioned through-hole for leakage test.
Attention: when not assembled correctly, solder can flow inside the receptacle.

**** Additional crimping points for self locking

Collar height and installation height

The installation height of the tip is always 10,5 mm (.413). The test probe can only be used with a receptacle.

Mechanical data

Working stroke: 4,0 mm (.157)
Maximum stroke: 5,3 mm (.209)
Spring force at work. stroke: 1,5 N (5.4oz)
Alternative: 0,3 N (1.1oz); 0,6 N (2.2oz);
 1,0 N (3.6oz); 2,25 (8.1oz); 3,0 N (10.8oz);
 5,0 N (18.1oz)

Electrical data

Current rating: 5 - 8 A
R_i typical: < 30 mΩ
 (** < 100 mΩ)

Operating temperature

Standard: -40° up to +80° C
****with spec. design. "MC":**
 -100° up to +200° C
 (1,5 N; 2,25 N; 3,0 N)

Recommended screw-in torque:
 Min.: 10 cNm / Max.: 20 cNm

Materials

Plunger: BeCu or Steel, gold-, rhodium or chemically nickel-plated
Barrel: Brass, gold-plated
Spring: Steel, gold-plated or stainless steel** (MC)
Receptacle: Brass, gold-plated

Mounting hole size

for KS-113 30 M2 and KS-113 30 M2-T
 in CEM1: ∅ 2,98 - 3,00 mm (.1173 - .1181)
 in FR4: ∅ 2,99 - 3,01 mm (.1177 - .1185)
for KS-113 30 M2-R and KS-113 M2-R-S
 in CEM1 and FR4: ∅ 3,00 - 3,02 mm (.1181 - .1189)

Available tip styles

Material	Tip style	Plating	Further versions	
			∅	∅ (inch)
2	01	R		
3	02	A	0,80 (.031) 1,00 (.039) 1,80 (.071) 3,00 (.118) 4,00 (.157)	
2	03	A		
3	03	A	4,00 R (.157)	
2	04	R	1,80 A (.071) 3,00 (.118)	
3	05	A	0,80 (.031) 1,40 (.055) 3,00 R (.118)	
3	55	R		
	Tip 4 mm (.157) longer			
3	06	A	1,60 (.063) 2,30 (.091) 4,00 (.157) 8,00 (.315)	
3	06	R	2,50 (.098) 3,00 (.118) 3,50 (.138) 4,00 (.157) 6,00 (.236)	NEW NEW
2	07	A		
3	07	R		NEW
3	12	A		
3	13	R		
2	14	R		
2	15*	A		
	Tip 2,5 mm (.098) longer			
2	17	R	1,80 (.071) 3,00 A (.118)	
3	19	A	3,00 (.118)	
3	72	A		
2	87	N	4,00 (.157)	
2	88	A		

* pressed-in steel tip in base plunger made of brass

Ordering example

Series	Tip material	Tip style	Tip diameter (1/100 mm)	Plating	Spring force (dN)	Collar height (mm)	Special designation alternative "MC"
	2 = Steel 3 = BeCu			A = Gold N = Nickel R = Rhodium			

Test probe:

G K S 1 1 3 3 0 6 2 3 0 R 1 5 0 2 M

Receptacles for GKS-113 ... M:

K S - 1 1 3 3 0 M 2 - R K S - 1 1 3 3 0 M 2 - T

Receptacles for leakage test***:

K S - 1 1 3 3 0 M 2