

Grid:
 ≥ 6,50 mm
 ≥ 260 Mil

Installation height with KS: 7,0 mm (.276)
Recommended stroke: 4,0 mm (.157)

Mounting and functional dimensions

Available tip styles

Material	Tip style	Plating	Further versions	
			∅	∅ (inch)
2 01*		N		
2 04		N		
2 05		N		
2 06		N		

* Angle of tip 60°

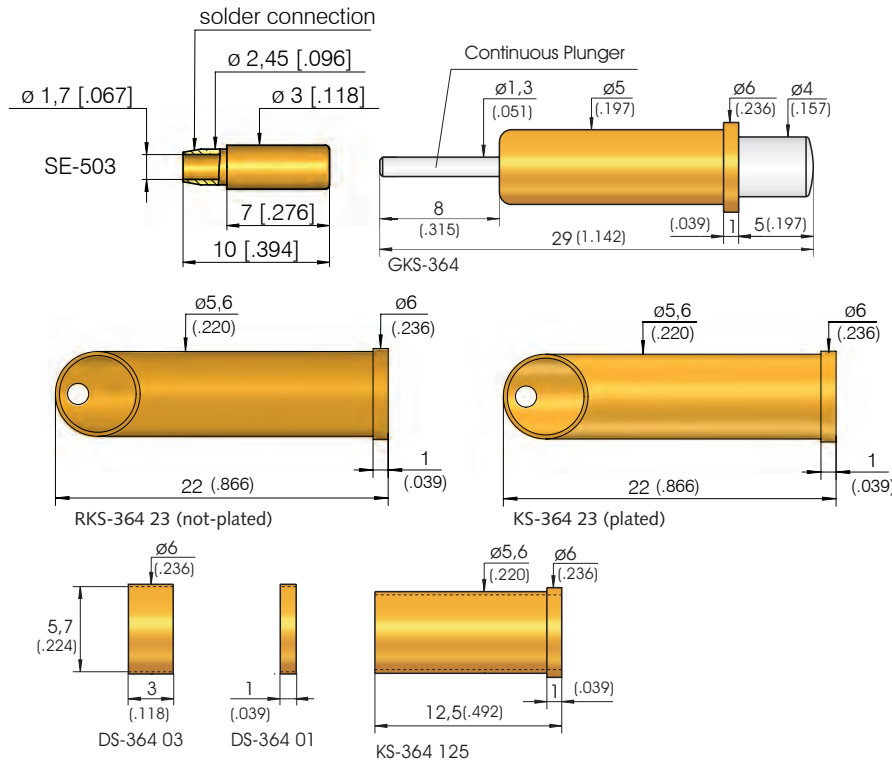

Mechanical data

Working stroke: 4,0 mm (.157)
Maximum stroke: 5,0 mm (.197)
Spring force at work. stroke: 1,5 N (5.4oz)
Alternative: 0,6 N (2.2oz); 3,0 N (10.8oz), 8,0 N (28.9oz)

Electrical data

Current rating, conn. to plunger: 15-20 A
Current rating, connection to KS: 5 - 8 A
R_i typical, connection to plunger: < 10 mΩ
R_i typical, connection to KS: < 30 mΩ
 (** < 100 mΩ)

Operating temperature

Standard: -40° up to +80° C
****with 1,5 and 3,0 N-spring:** -100° up to +200° C

Materials

Plunger: Steel, nickel-plated
Barrel: Brass, gold-plated
Spring: Steel, gold-plated or stainless steel**

Receptacles:

RKS-364 23: Brass, not plated
 KS-364 125: Brass, gold-plated

Mounting hole size

with receptacle: $\phi 5,59 - 5,60$ mm (.2201 - .2205)
without receptacle: $\phi 5,00$ mm (.1969)

Ordering example

	Series	Tip material 2 = Steel	Tip style	Tip diameter (1/100 mm)	Plating N = Nickel	Spring force (dN)	Collar height (mm)
Test probe:	G K S	3	6 4	2 0 4	4 0 0	N	1 5 0 1
Receptacles:	R K S - 3 6 4 2 3		K S - 3 6 4 2 3				K S - 3 6 4 1 2 5
Spacer for receptacle:	D S - 3 6 4 0 3						
Lamellar plug: (for plugging onto the end of the plunger)	S E - 5 0 3						