



# CUSTOMER APPROVAL SHEET

<b>Company Name</b>	
<b>MODEL</b>	A070SN01 V0
<b>CUSTOMER APPROVED</b>	

- APPROVAL FOR SPECIFICATIONS ONLY (Spec. Ver. 0.5)
- APPROVAL FOR SPECIFICATIONS AND ES SAMPLE (Spec. Ver. 0.5)
- APPROVAL FOR SPECIFICATIONS AND CS SAMPLE (Spec. Ver. 0.5)
- CUSTOMER REMARK :

P/N : \_\_\_\_\_

Comment :



Doc. version :	0.5
Total pages :	28
Date :	2009/02/12

# Product Specification

## 7.0" COLOR TFT-LCD MODULE

**Model Name : A070SN01 V0**

---

**Planned Lifetime:** From 2009/Feb. To 2010/Feb.

**Phase-out Control:** From 2009/Sep. To 2010/Feb.

**EOL Schedule:** 2010/Feb.

---

< >Preliminary Specification

< ◆ >Final Specification

Note: The content of this specification is subject to change.

© 2008 AU Optronics  
All Rights Reserved,  
Do Not Copy.

Record of Revision

Version	Revise Date	Page	Content
0.0	2008/11/25	All	First Draft.
0.1	2008/12/26	4-5	Modify front and rear drawing
0.2	2009/01/09	4-5	Modify BLU connector drawing
0.3	2009/01/15	3	Color depth
		6-7	Update pin assignment pin 44, 30 and 31
		9	Update Absolut power rating
		11	LED driving method
		15	Power on/off sequence
		16	Modify view angle
		24	Update gamma voltage
		25	Update VCOM circuit
		26	Update application note J3
0.4	2009/02/06	3	Modify Weight data
		16	Update Wx/Wy Chromaticity
0.5	2009/02/11	13	Update input timing
		10-11	Update VcomDC Update current and power consumption

## Contents

<b>A. General Information</b>	<b>3</b>
<b>B. Outline Dimension</b>	<b>4</b>
1. TFT-LCD Module – Front View	4
2. TFT-LCD Module – Rear View	5
<b>C. Electrical Specifications</b>	<b>6</b>
1. TFT LCD Panel Pin Assignment	6
2. Absolute Maximum Ratings	9
<b>D. Electrical DC Characteristics</b>	<b>10</b>
1. Current Consumption (AGND=GND=0V)	11
2. Backlight Driving Conditions	11
<b>E. Electrical AC Characteristics</b>	<b>12</b>
1. Signal AC Characteristics	12
2. Input Timing Setting	13
3. Vertical timing	13
<b>F. Power On/Off Characteristics</b>	<b>14</b>
Recommended Power On/off Sequence	14
<b>G. Optical Specification</b>	<b>15</b>
<b>H. Reliability Test Items</b>	<b>18</b>
<b>I. Packing and Marking</b>	<b>21</b>
1. Packing Form	21
2. Module/Panel Label Information	22
3. Carton Label Information	22
<b>J. Application Note</b>	<b>23</b>
1. Gamma voltage suggested circuit is as follows	23
2. Vcom buffer suggested circuit is as follows	24
3. Application Circuit	25
<b>K. Precautions</b>	<b>27</b>

## A. General Information

This product is for portable DVD and digital photo frame application.

NO.	Item	Unit	Specification	Remark
1	Screen Size	inch	7.0 (Diagonal)	
2	Display Resolution	dot	800(H)×600 (V)	
3	Overall Dimension	mm	154(H) × 119.2(V) × 5.1(T)	Note 1
4	Active Area	mm	141.6(H)×106.2(V)	
5	Pixel Pitch	mm	0.177(H)×0.177(V)	
6	Color Configuration	--	R. G. B. Stripe	Note 2
7	Color Depth	--	16M Colors	Note 3
8	NTSC Ratio	%	50	
9	Display Mode	--	Normally White	
10	Panel surface Treatment	--	Anti-Glare	
11	Weight	g	123	
12	Backlight Power Consumption	W	1.2	

Note 1: Not include backlight cable and FPC. Refer next page to get further information.

Note 2: Below figure shows dot stripe arrangement.

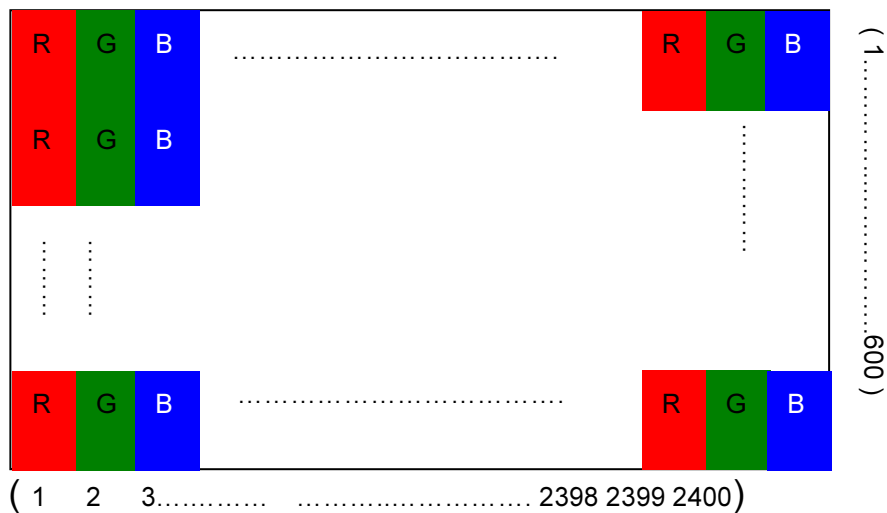

Note 3: The full color display depends on 24-bit data signal (pin 4~27).

## B. Outline Dimension

### 1. TFT-LCD Module – Front View

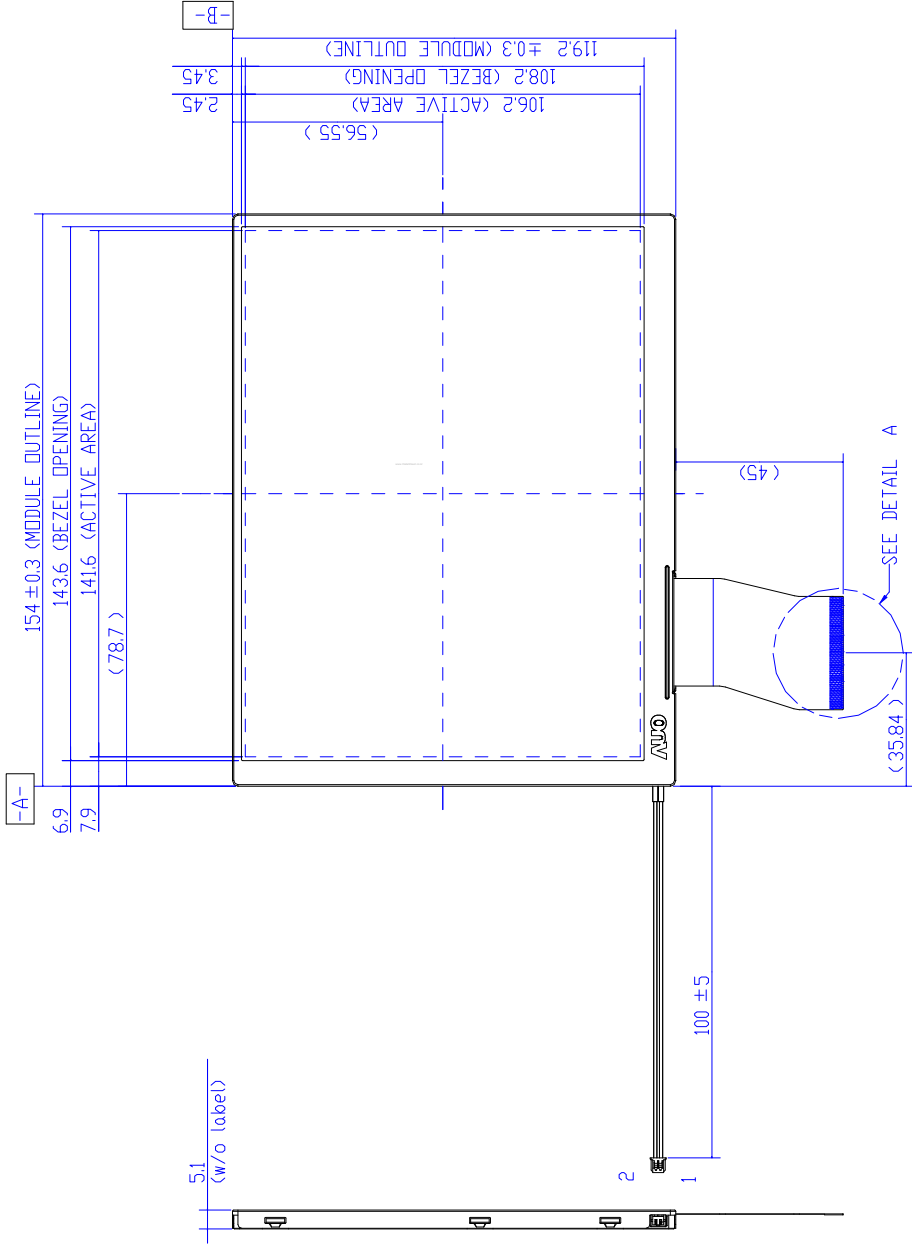

## 2. TFT-LCD Module – Rear View

NOTES:  
1.CONNECTOR:ENTERY H201K-P02N-02B(MOLEX 51021-0200 compatible)  
PIN1:(+) ,PIN2:(-)  
2.GENERAL TOLERANCE:±0.3mm

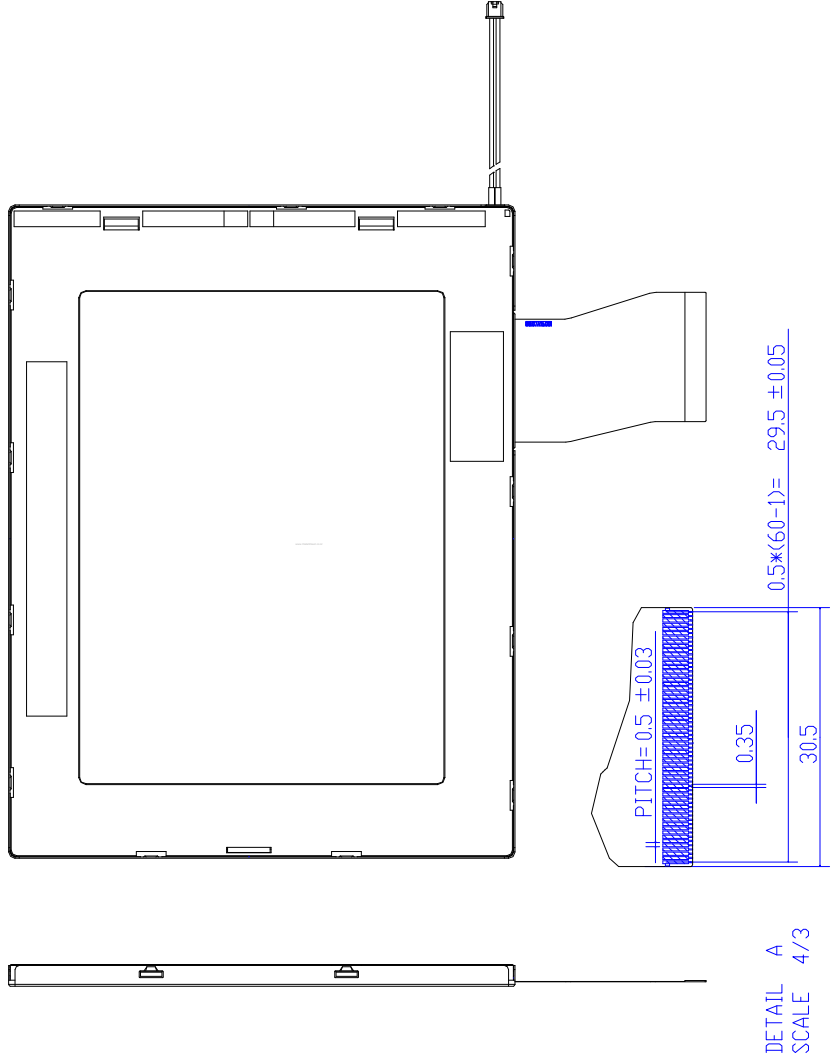

## C. Electrical Specifications

### 1. TFT LCD Panel Pin Assignment

Recommended connector :

Pin No.	Symbol	I/O	Description	Remark
1	AGND	P	Analog Ground	
2	AVDD	P	Analog Power	
3	VDD	P	Digital Power	
4	R0	I	Data input (LSB)	
5	R1	I	Data input	
6	R2	I	Data input	
7	R3	I	Data input	
8	R4	I	Data input	
9	R5	I	Data input	
10	R6	I	Data input	
11	R7	I	Data input (MSB)	
12	G0	I	Data input (LSB)	
13	G1	I	Data input	
14	G2	I	Data input	
15	G3	I	Data input	
16	G4	I	Data input	
17	G5	I	Data input	
18	G6	I	Data input	
19	G7	I	Data input (MSB)	
20	B0	I	Data input (LSB)	
21	B1	I	Data input	
22	B2	I	Data input	
23	B3	I	Data input	
24	B4	I	Data input	
25	B5	I	Data input	
26	B6	I	Data input	
27	B7	I	Data input (MSB)	
28	DCLK	I	Clock input	
29	DE	I	Data enable signal	
30	NC	-	No connect	
31	NC	-	No connect	



32	Left./Right (optional)	I	Left./Right	Note 1
33	Up/Down (optional)	I	Up/Down	Note 1
34	Display	H/L	H = Display on, L = Display off	
35	NC	-	No connect	
36	VDD	P	Digital Power	
37	NC	-	No connect	
38	GND	P	Digital ground	
39	AGND	P	Analog ground	
40	AVDD	P	Analog Power	
41	VCOM	I	For external VCOM DC input	
42	DITH	I/O	Dithering setting DITH = "L" 6bit resolution(LSB last 2 bits of input data truncated) DITH = "H" 8bit resolution(Default setting)	
43	NC	I/O	No connect	
44	VCOM	I	For external VCOM DC input	
45	V10	P	Gamma correction voltage reference	
46	V9	P	Gamma correction voltage reference	
47	V8	P	Gamma correction voltage reference	
48	V7	P	Gamma correction voltage reference	
49	V6	P	Gamma correction voltage reference	
50	V5	P	Gamma correction voltage reference	
51	V4	P	Gamma correction voltage reference	
52	V3	P	Gamma correction voltage reference	
53	V2	P	Gamma correction voltage reference	
54	V1	P	Gamma correction voltage reference	
55	NC	-	No connect	
56	VGH	P	Positive power for TFT	
57	VDD	P	Digital Power	
58	VGL	P	Negative power for TFT	
59	GND	P	Digital Ground	
60	<b>NC</b>	-	No connect	

I: Input pin; P: Power pin; G: Ground pin; C: capacitor pin

Note 1: Option A: Up to down (UPDN = H), left to right (SHLR = H).

Option B: down to up (UPDN = L), right to left (SHLR = L).

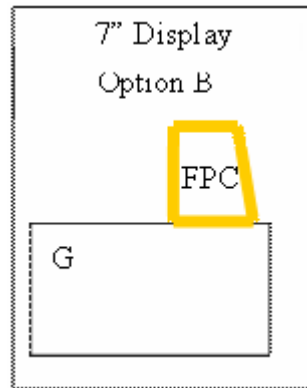
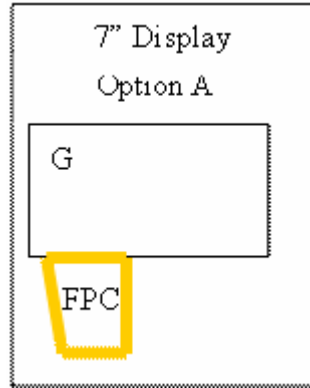

## 2. Absolute Maximum Ratings

Item	Symbol	Condition	Min.	Max.	Unit	Remark
Power voltage	VDD	GND=0	-0.3	+5.0	V	
	AVDD	GND=0	-0.3	+14.0	V	
	VGH	GND=0	-0.3	42	V	
	VGL		-20	0.3	V	
Storage temperature	Tstg	-	-20	70	°C	Ambient temperature
Operating	Topa	-	-10	60	°C	Ambient temperature

Note 1: Functional operation should be restricted under ambient temperature (25°C).

Note2: Maximum ratings are those values beyond which damages to the device may occur. Functional operation should be restricted to the limits in the Electrical Characteristics chapter.

## D. Electrical DC Characteristics

Item	Symbol	Min.	Typ.	Max.	Unit	Remark	
Power supply	V <sub>DD</sub>	3.1	3.3	3.5	V		
	AV <sub>DD</sub>	11.5	11.6	11.8	V		
	V <sub>GH</sub>	14	15	16	V		
	V <sub>GL</sub>	-7.5	-7	-6.5	V		
Power Consumption	P	-	1.2	-	mW	Black Pattern	
VCOM	V <sub>CDC</sub>	-	4.9	-	V	DC component	
Input signal	H Level	V <sub>IH</sub>	0.7*VDD	-	VDD	V	
	L Level	V <sub>IL</sub>	0	-	0.3*VDD	V	
Input level of V1~V5	V <sub>X</sub>	0.4*AVDD	-	AVDD-0.1		Positive gamma correction voltage Note 1	
Input level of V6~V10	V <sub>X</sub>	0.1	-	0.6*AVDD		Negative gamma correction voltage Note 1	

Note 1 : AGND <V10<V9V<8V7<V6<V5<V4<V3<V2<V1<AVDD

### 1. Current Consumption (AGND=GND=0V)

Parameter	Symbol	Condition	Min.	Typ.	Max.	Unit	Remark
Input current for VDD	IVDD	VDD=3.3V	-	17	25	mA	Under black pattern
Input current for AVDD	IAVDD	AVDD = 11.6V	-	25	30	mA	
Input current for VGH	IVGH	VGH=15V	-	0.2	0.4	mA	
Input current for VGL	IVGL	VGL= -7V		-0.2	-0.4	mA	
Input current for VCOM	IVCOM	VCOM= xV		0.004	0.010	mA	

### 2. Backlight Driving Conditions

The backlight (LED module, Note 1) is suggested to drive by constant current with typical value.

Parameter	Symbol	Min.	Typ.	Max.	Unit	Remark
LED light bar Voltage	IL	-	120	-	mA	Note 1
Power Consumption	PBL	-	1.2	-	W	Note 1
LED Life Time	LL	10,000	--	--	Hr	Note 2, 3

Note 1: The LED driving condition is defined for LED module (18 LED).

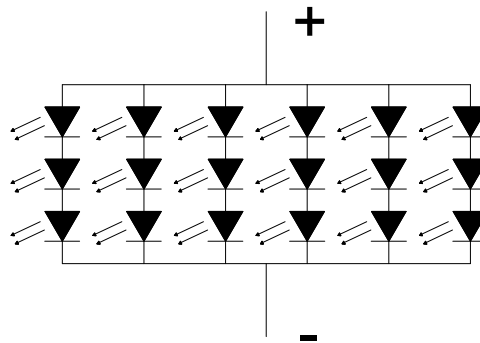

Note 2: Define “LED Lifetime”: brightness is decreased to 50% of the initial value. LED Lifetime is restricted under normal condition, ambient temperature = 25°C and LED lightbar current = 120mA.

Note 3: If it uses larger LED lightbar voltage more than 120mA, it maybe decreases the LED lifetime.

## E. Electrical AC Characteristics

### 1. Signal AC Characteristics

Parameter	Symbol	Min.	Typ.	Max.	Unit	Remark
DCLK duty cycle	--	40	50	60	%	$t_{cw} / t_{DCLK} \times 100\%$
DE setup time	$T_{est}$	8	--	--	ns	
Data setup time	$t_{dst}$	8	--	--	ns	
Data hold time	$t_{dhd}$	8	--	--	ns	
VSD setup time	$t_{vst}$	8	--	--	ns	
VSD hold time	$t_{vhhd}$	8	--	--	ns	
HSD setup time	$t_{hst}$	8	--	--	ns	
HSD hold time	$t_{hhhd}$	8	--	--	ns	

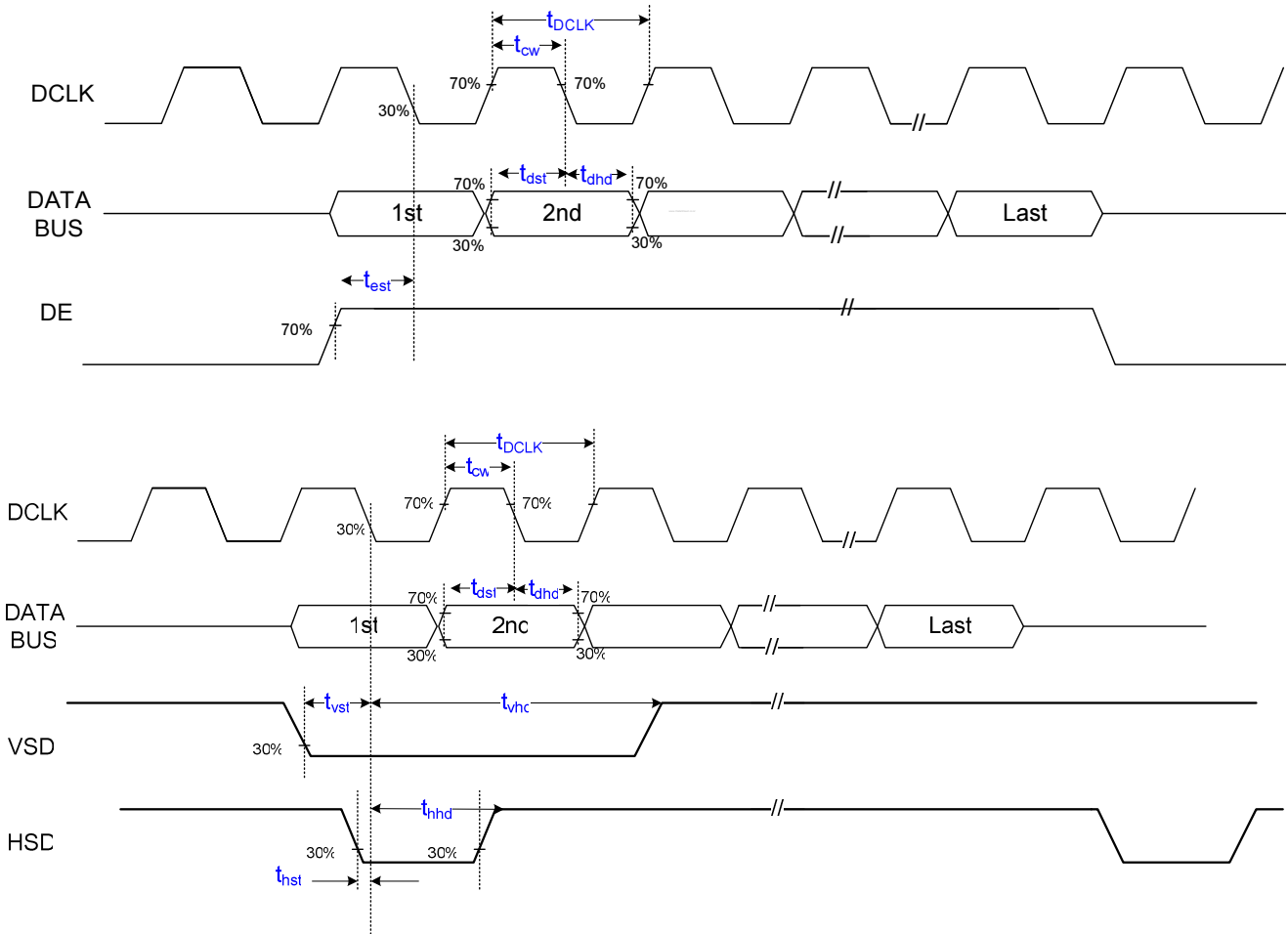

## 2. Input Timing Setting

### Horizontal Timing :

Parameter	Symbol	Min.	Typ.	Max.	Unit.	Remark
DCLK frequency	$F_{DCLK}$	35	40	45	MHz	
DCLK period	$T_{DCLK}$	22	25	28	ns	
Hsync period (= $T_{HD} + T_{HBL}$ )	$T_H$	-	1000	-	DCLK	
Active Area	$T_{HD}$	-	800	-	DCLK	
Horizontal blanking (= $T_{HF} + T_{HE}$ )	$T_{HBL}$		200		DCLK	

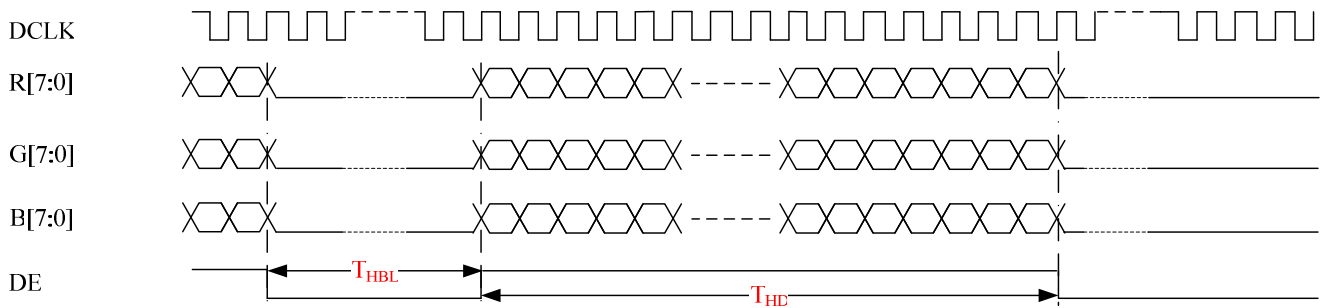

Horizontal input timing (DE mode)

## 3. Vertical timing:

Parameter	Symbol	Min.	Typ.	Max.	Unit.	Remark
Vsync period (= $T_{VD} + T_{VBL}$ )	$T_V$	-	660	-	Th	
Active lines	$T_{VD}$	-	600	-		
Vertical blanking (= $T_{VF} + T_{VE}$ )	$T_{VBL}$	-	60	-	Th	

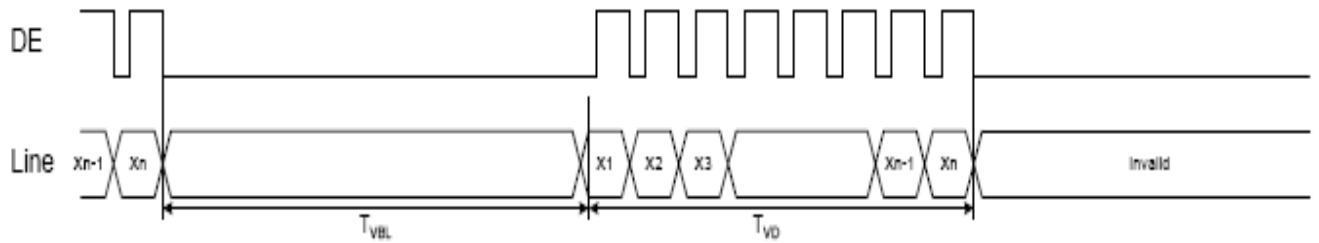

Vertical timing (DE mode)

## F. Power On/Off Characteristics

### Recommended Power On/off Sequence

The suggested LCD power on/off sequence is below:

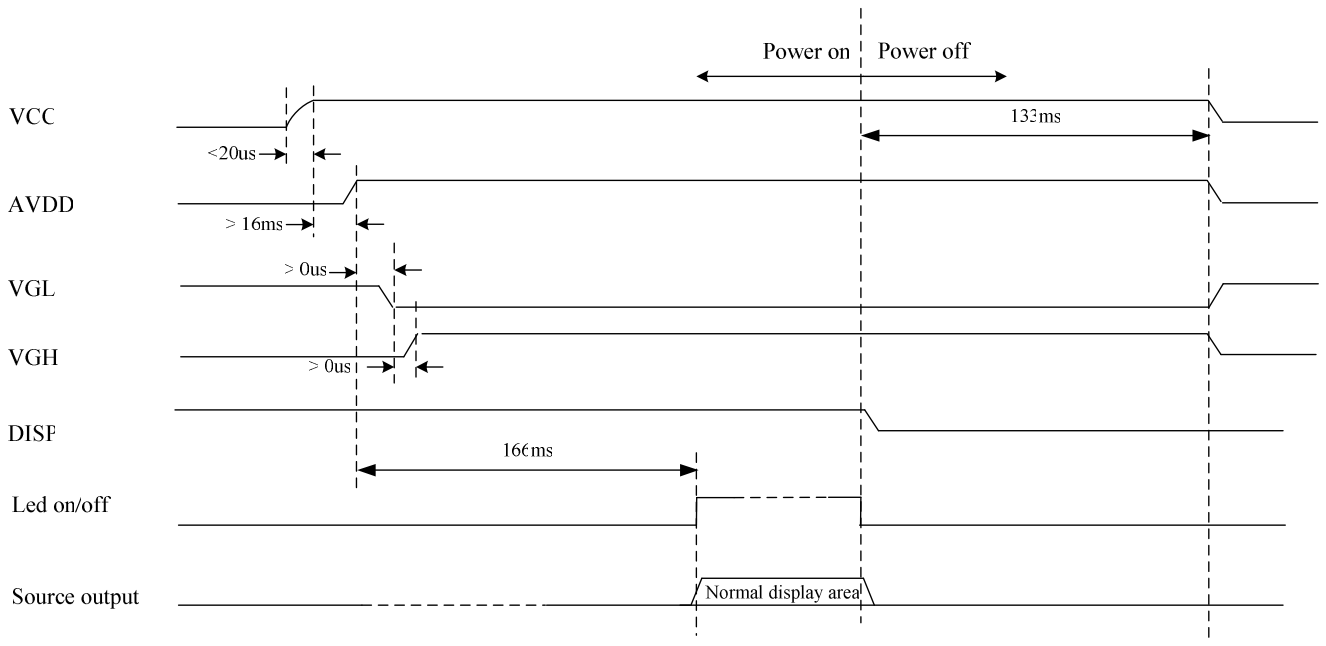



## G. Optical Specification

All optical specification is measured under typical condition (Note 1, 2)

Item	Symbol	Condition	Min.	Typ.	Max.	Unit	Remark
Response Time							
Rise	Tr	$\theta=0^\circ$	--	3	6	ms	Note 3
Fall	Tf		--	13	26	ms	
Contrast ratio	CR	At optimized viewing angle	400	500	--		Note 4
Viewing Angle	Top Bottom Left Right	$CR \geq 10$		60		deg.	Note 5
				60			
				70			
				70			
Brightness	$Y_L$	$\theta=0^\circ$	220	250	--	cd/m <sup>2</sup>	Note 6
Chromaticity	White	X	$\theta=0^\circ$	0.25	0.30	0.35	
		Y	$\theta=0^\circ$	0.27	0.32	0.37	
	Red	X	$\theta=0^\circ$	0.53	0.58	0.63	
		Y	$\theta=0^\circ$	0.28	0.33	0.38	
	Green	X	$\theta=0^\circ$	0.28	0.33	0.38	
		Y	$\theta=0^\circ$	0.51	0.56	0.61	
	Blue	X	$\theta=0^\circ$	0.10	0.15	0.20	
		Y	$\theta=0^\circ$	0.06	0.11	0.16	
Uniformity	$\Delta Y_L$	%	70	75	--	%	Note 7

Note 1. Ambient temperature =25°C, and LED lightbar current  $I_L = 120$  mA. To be measured in the dark room.

Note 2. To be measured on the center area of panel with a viewing cone of 1° by Topcon luminance meter BM-5A, after 15 minutes operation.

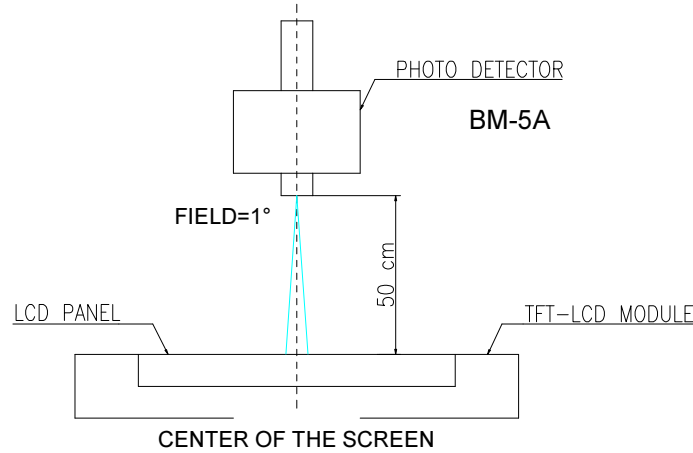

Note 3. Definition of response time:

The output signals of photo detector are measured when the input signals are changed from "black" to "white"(falling time) and from "white" to "black"(rising time), respectively.

The response time is defined as the time interval between the 10% and 90% of amplitudes. Refer to figure as below.

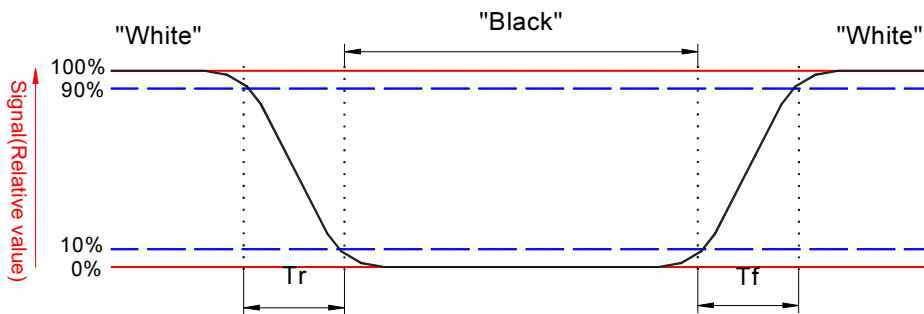

Note 4. Definition of contrast ratio:

Contrast ratio is calculated with the following formula.

$$\text{Contrast ratio (CR)} = \frac{\text{Photo detector output when LCD is at "White" status}}{\text{Photo detector output when LCD is at "Black" status}}$$

Note 5. Definition of viewing angle,  $\theta$ , Refer to figure as below.

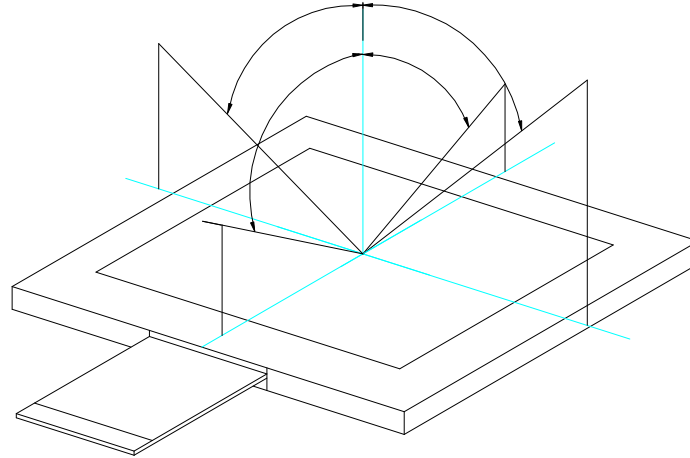

Note 6. Measured at the center area of the panel when all the input terminals of LCD panel are electrically opened.

Note 7: Luminance Uniformity of these 9 points is defined as below:

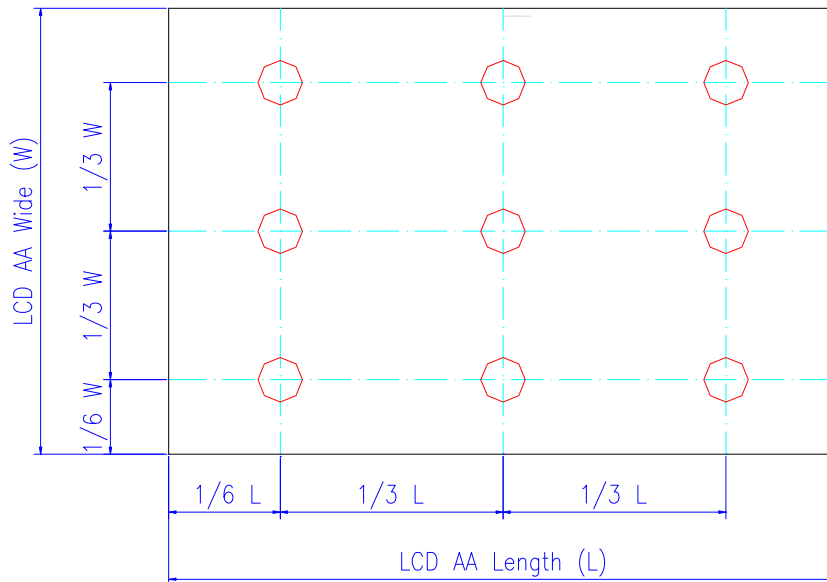

$$\text{Uniformity} = \frac{\text{minimum luminance in 9 points (1-9)}}{\text{maximum luminance in 9 points (1-9)}}$$

## H. Reliability Test Items

No.	Test items	Conditions		Remark
1	High Temperature Storage	Ta= 70°C	240Hrs	
2	Low Temperature Storage	Ta= -20°C	240Hrs	
3	High Temperature Operation	Tp= 60°C	240Hrs	
4	Low Temperature Operation	Ta= -10°C	240Hrs	
5	High Temperature & High Humidity	Tp= 50°C . 80% RH	240Hrs	Operation
6	Heat Shock	-30°C ~70°C, 50 cycle, 1Hrs/cycle		Non-operation
7	Electrostatic Discharge	Contact = ± 4 kV, class B Air = ± 8 kV, class B		Note 4
8	Image Sticking	25°C, 4hrs		Note 5
9	Vibration	Frequency range	: 10~55Hz	JIS C7021, A-10 Condition A
		Stroke	: 1.5mm	
		Sweep	: 10 ~ 55 ~ 10Hz	
		2 hours for each direction of X,Y,Z		
		(6 hours for total)		
10	Mechanical Shock	100G . 6ms, ±X,±Y,±Z 3 times for each direction		Non-operation JIS C7021, A-7 condition C
11	Vibration (With Carton)	Random vibration: 0.015G <sup>2</sup> /Hz from 5~200Hz -6dB/Octave from 200~500Hz		IEC 68-34
12	Drop (With Carton)	Height: 60cm 1 corner, 3 edges, 6 surfaces		
13	Pressure	5kg, 5sec		Note 6

Note 1. Ta: Ambient Temperature. Tp: Panel Surface Temperature

Note 2. In the standard conditions, there is not display function NG issue occurred. All the cosmetic specification is judged before the reliability stress.

Note 3. All the cosmetic specification is judged before the reliability stress.

Note4. All test techniques follow IEC6100-4-2 standard.

Pls be noticed that product needs grounding design on customer system side.

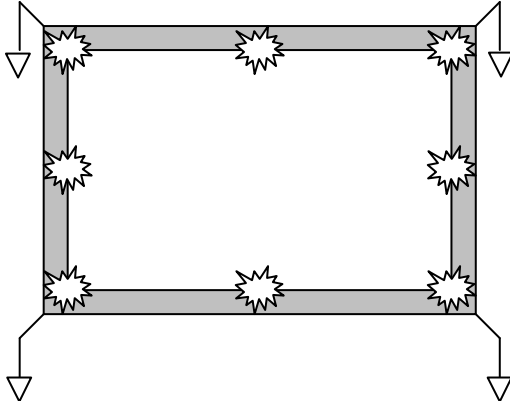
Test Condition		Note
<p>Pattern</p>		
<p>Procedure And Set-up</p>	<p>Contact Discharge : 330Ω, 150pF, 1sec, 8 point, 25times/point            Air Discharge : 330Ω, 150pF, 1sec, 8 point, 25times/point</p> 	
<p>Criteria</p>	<p>B – Some performance degradation allowed. No data lost.            Self-recoverable hardware failure.</p>	
<p>Others</p>	<ol style="list-style-type: none"> <li>1. Gun to Panel Distance</li> <li>2. No SPI command, keep default register settings.</li> </ol>	

Note 5. Operate with chess board pattern as figure and lasting time and temperature as the conditions. Then judge with 50% gray level, the mura is less than JND 2.5

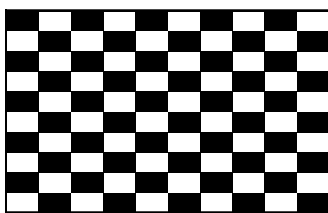

Note 6. The panel is tested as figure. The jig is  $\phi 10$  mm made by Cu with rubber and the loading speed is 3mm/min on position A~E. After the condition, no glass crack will be found and panel function check is OK.(no guarantee LC mura · LC bubble)

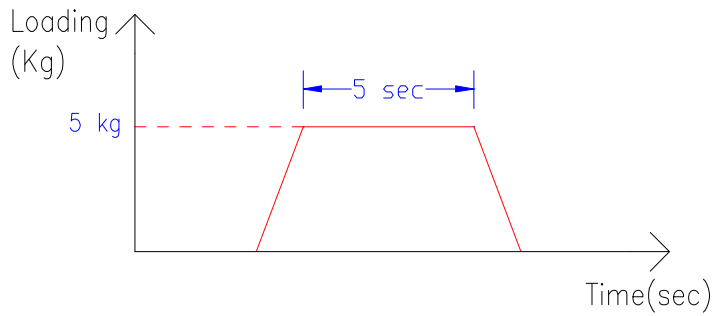
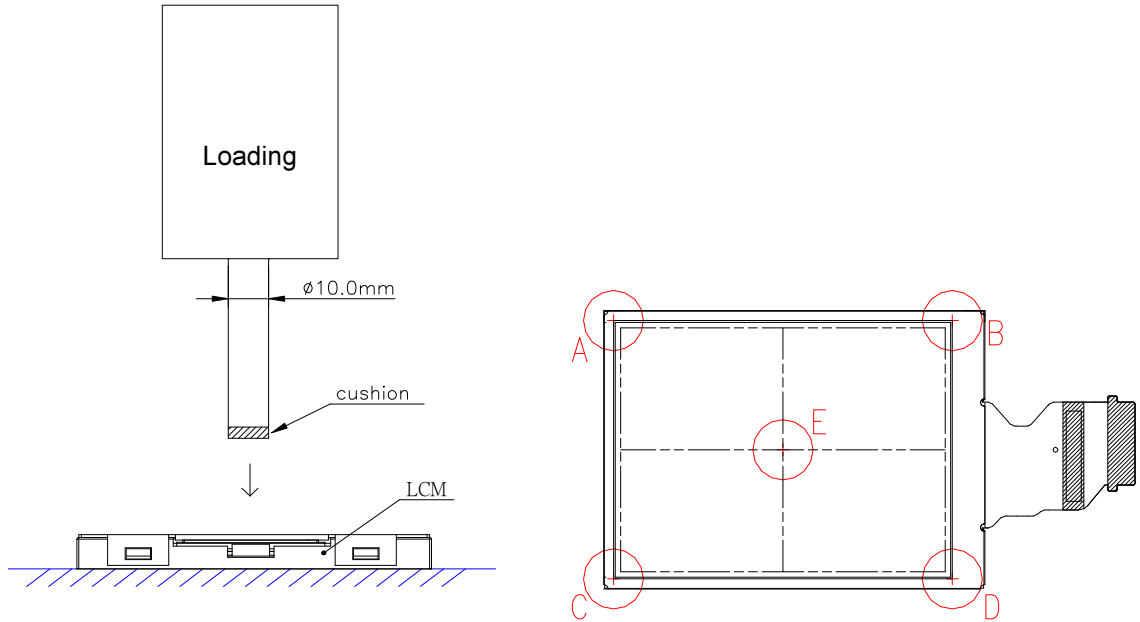

## I. Packing and Marking

### 1. Packing Form

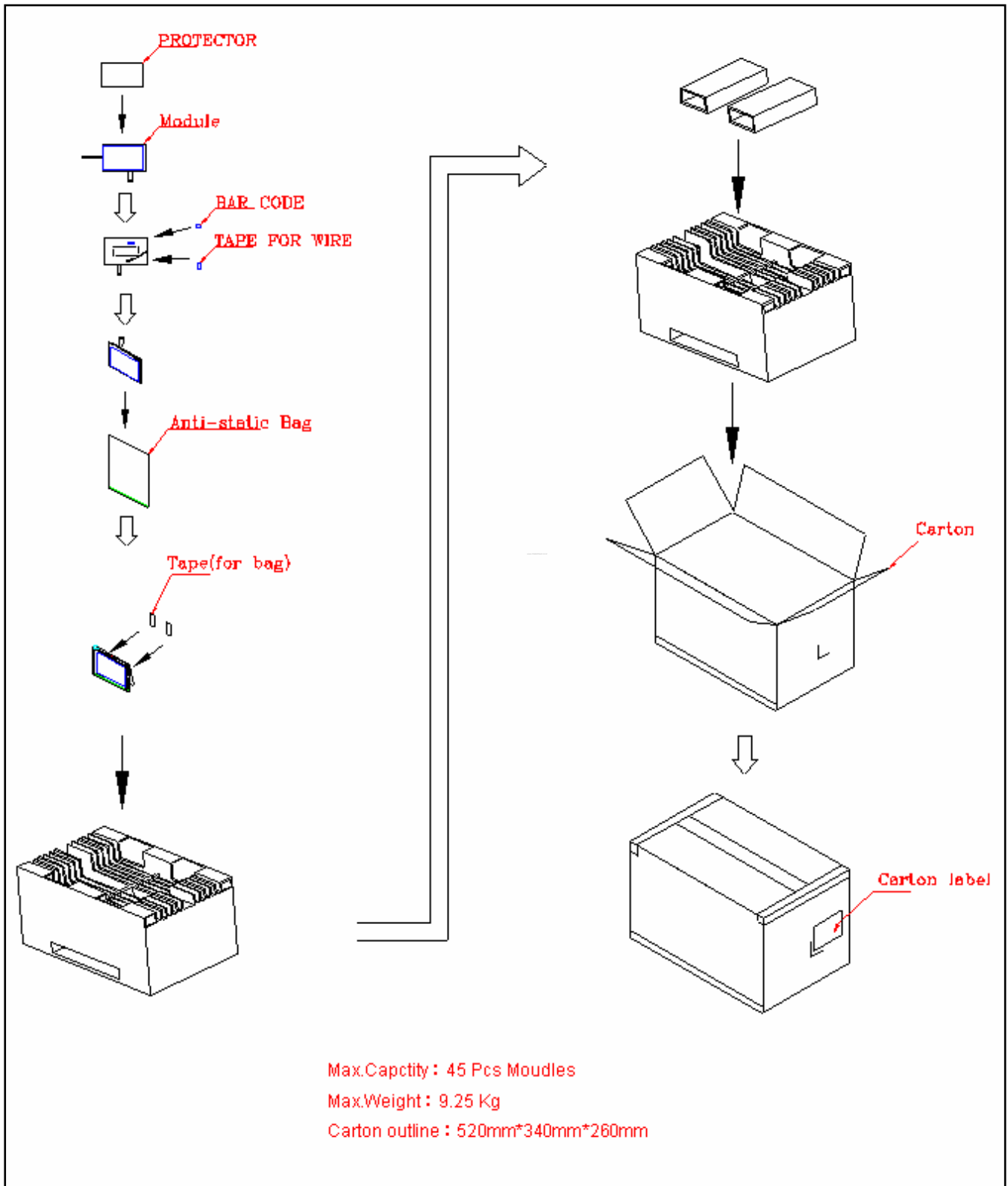

## 2. Module/Panel Label Information

The module/panel (collectively called as the “Product”) will be attached with a label of Shipping Number which represents the identification of the Product at a specific location. Refer to the Product outline drawing for detailed location and size of the label. The label is composed of a 22-digit serial number and printed with code 39/128 with the following definition:

ABCDEFGHIJKLMNOPQRSTUV

- For internal system usage and production serial numbers.
- AUO Module or Panel factory code, represents the final production factory to complete the Product
- Product version code, ranging from 0~9 or A~Z (for Version after 9)
- Week Code, the production week when the product is finished at its production process

## 3. Carton Label Information

The packing carton will be attached with a carton label where packing Q'ty, AUO Model Name, AUO Part Number, Customer Part Number (Optional) and a series of Carton Number in 13 or 14 digits are printed. The Carton Number is appearing in the following format:

ABC-DEFG-HIJK-LMN

- DEFG appear after first "-" represents the packing date of the carton
- Date from 01 to 31
- Month, ranging from 1~9, A~C. A for Oct, B for Nov and C for Dec.
- A.D. year, ranging from 1~9 and 0. The single digit code represents the last number of the year

Refer to the drawing of packing format for the location and size of the carton label.



## J. Application Note

### 1. Gamma voltage suggested circuit is as follows

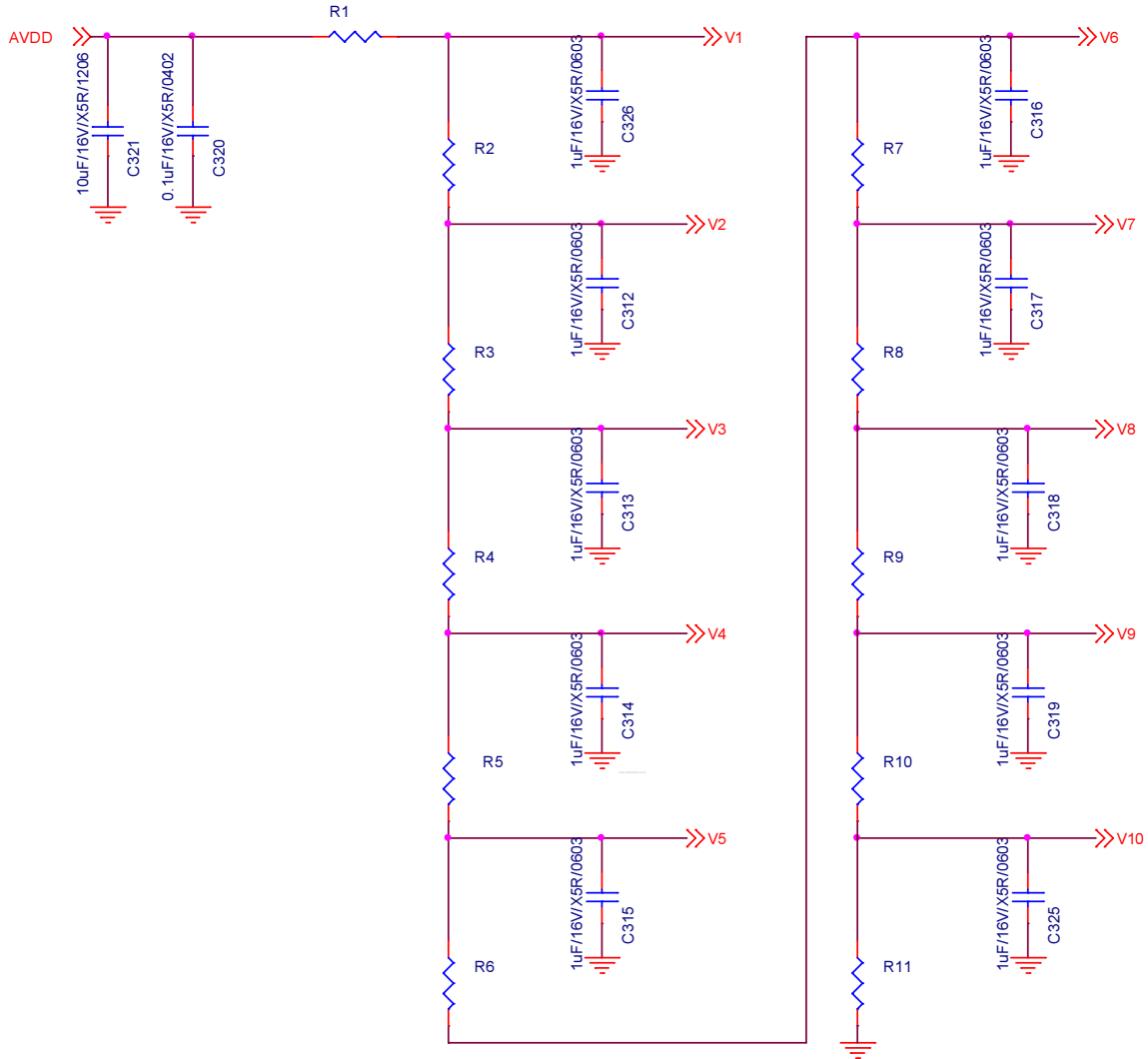

2 <sup>nd</sup> Preliminary	
2.20K	R1
4.99K	R2
2.20K	R3
1.40K	R4
3.00K	R5
6.49K	R6
3.00K	R7
1.40K	R8
2.32K	R9
4.99K	R10
4.02K	R11

2. Vcom buffer suggested circuit is as follows

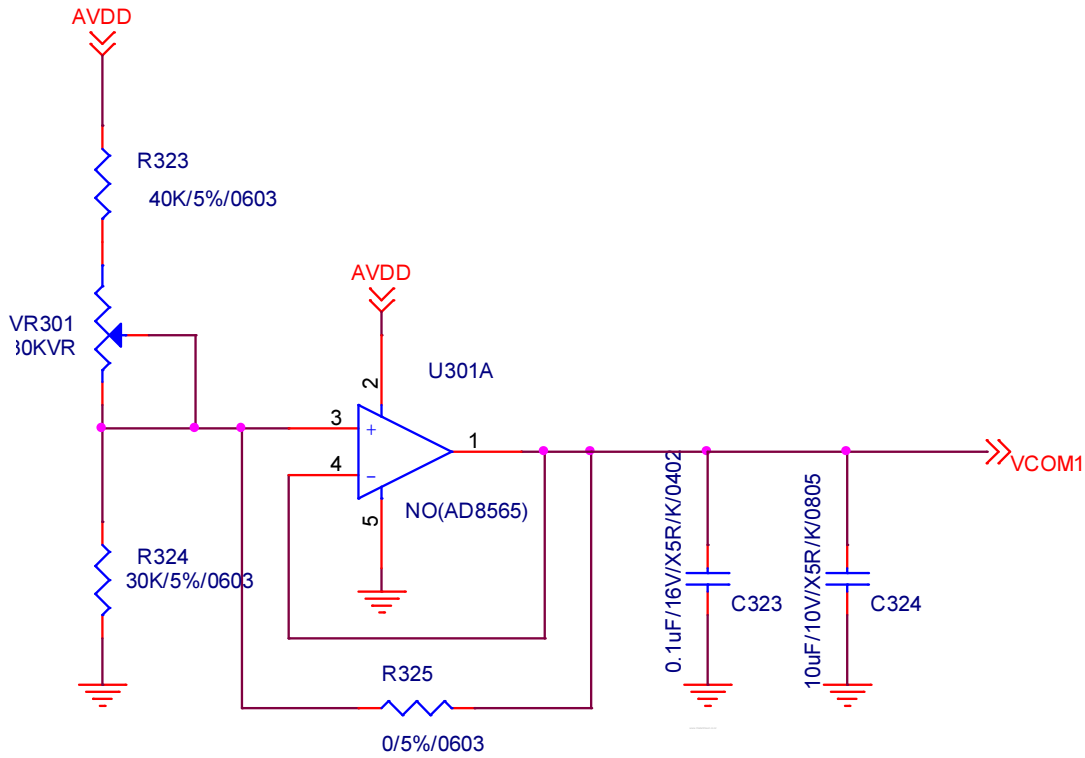

### 3. Application Circuit

J1

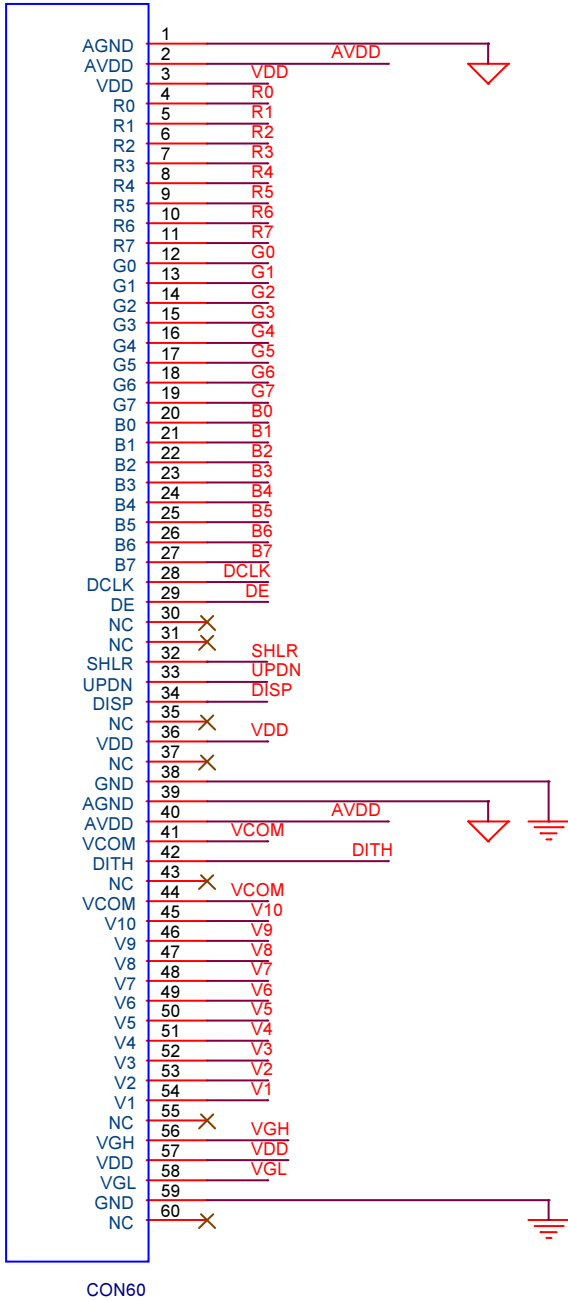

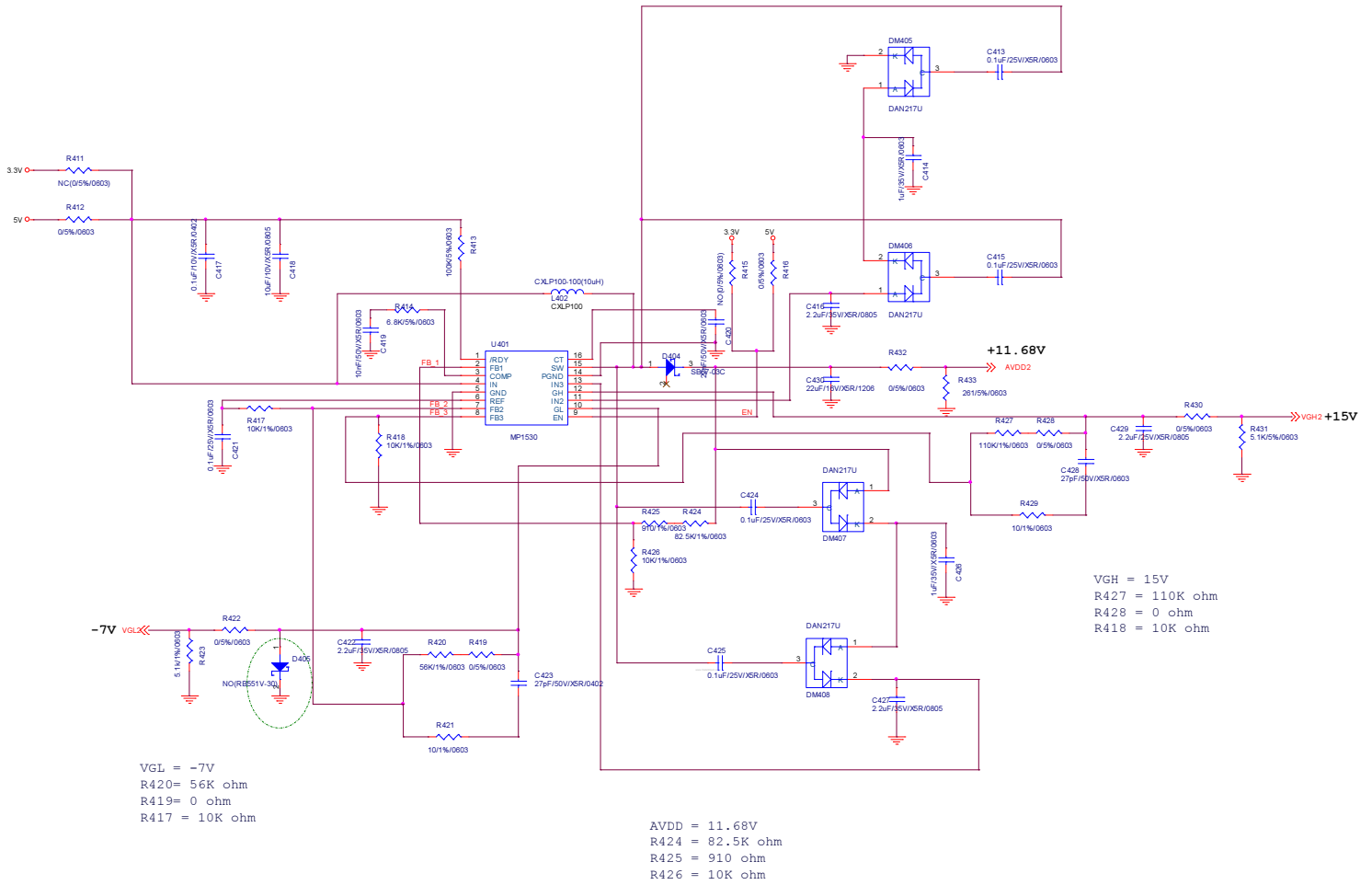

## K. Precautions

1. Do not twist or bend the module and prevent the unsuitable external force for display module during assembly.
2. Adopt measures for good heat radiation. Be sure to use the module within the specified temperature.
3. Avoid dust or oil mist during assembly.
4. Follow the correct power sequence while operating. Do not apply the invalid signal, otherwise, it will cause improper shut down and damage the module.
5. Less EMI: it will be more safety and less noise.
6. Please operate module in suitable temperature. The response time & brightness will drift by different temperature.
7. Avoid to display the fixed pattern (exclude the white pattern) in a long period, otherwise, it will cause image sticking.
8. Be sure to turn off the power when connecting or disconnecting the circuit.
9. Polarizer scratches easily, please handle it carefully.
10. Display surface never likes dirt or stains.
11. A dewdrop may lead to destruction. Please wipe off any moisture before using module.
12. Sudden temperature changes cause condensation, and it will cause polarizer damaged.
13. High temperature and humidity may degrade performance. Please do not expose the module to the direct sunlight and so on.
14. Acetic acid or chlorine compounds are not friends with TFT display module.
15. Static electricity will damage the module, please do not touch the module without any grounded device.
16. Do not disassemble and reassemble the module by self.
17. Be careful do not touch the rear side directly.
18. No strong vibration or shock. It will cause module broken.
19. Storage the modules in suitable environment with regular packing.
20. Be careful of injury from a broken display module.
21. Please avoid the pressure adding to the surface (front or rear side) of modules, because it will cause the display non-uniformity or other function issue.