

RF-PW16-B SERIES

Description

- ◆ Viewing angle:120 deg
- ◆ The materials of the LED dice is InGaN/GaN
- ◆ 14.2mm×8.0mm×5.2mm
- ◆ RoHS compliant lead-free soldering compatible

Package Outline

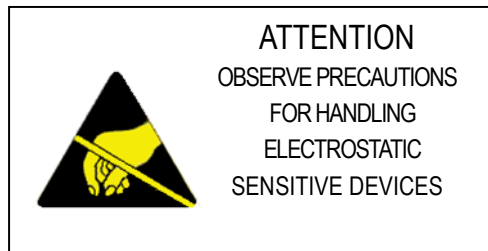
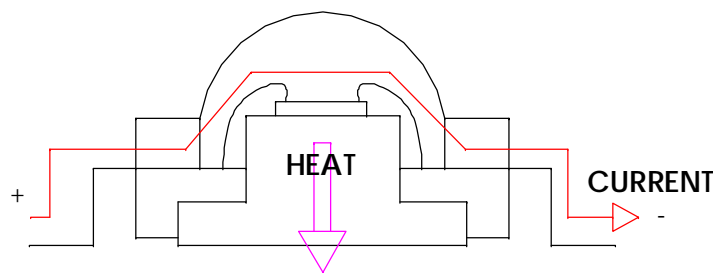
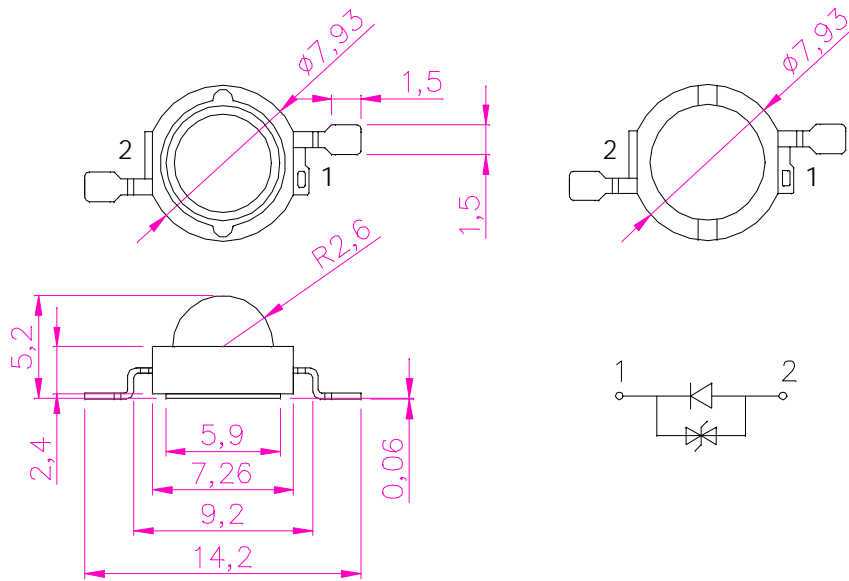

NOTES:

1. All dimensions are in millimeters (inches);
2. Tolerances are $\pm 0.3\text{mm}$ (0.012inch) unless otherwise noted.

Absolute maximum ratings at Ta=25°C

Parameter	Symbol	Value	Unit
Forward DC current	If	700	mA
Reverse DC voltage	Vr	5	V
Operating temperature range	Top	-40 ~+100	°C
Storage temperature range	Tstg	-40~+100	°C
Peak pulsing current	Ifp	1000	mA
Thermal Resistance	Rthj-a	10	°C/W

Electro-optical characteristics at Ta=25°C

Parameter	Test Condition	Symbol	Value			Unit
			Min.	Typ.	Max.	
Forward voltage	If=350mA	Vf	2.8	--	3.8	V
	If=700mA		3.5	--	4.5	
Luminous flux	If=350mA	Φ	80	--	120	lm
	If=700mA		140	--	220	
Luminous intensity	If=350mA	IV	26000	--	39000	mcd
	If=700mA		38000	--	70000	
Reverse current	Vr=5V	Ir	--	--	10	μA
Color Render Index	If=350mA	CRI	60	--	90	--
Correlated Color Temperature	If=350mA	CCT	2800	--	10000	K

NOTE: (Tolerance: Φ ±10% , X/Y ±0.01 , Vf ±0.1V)

IFP Conditions : Pulse Width ≤ 10msec. and Duty ≤ 1/10.

Bin Information

PW Series Bin Information

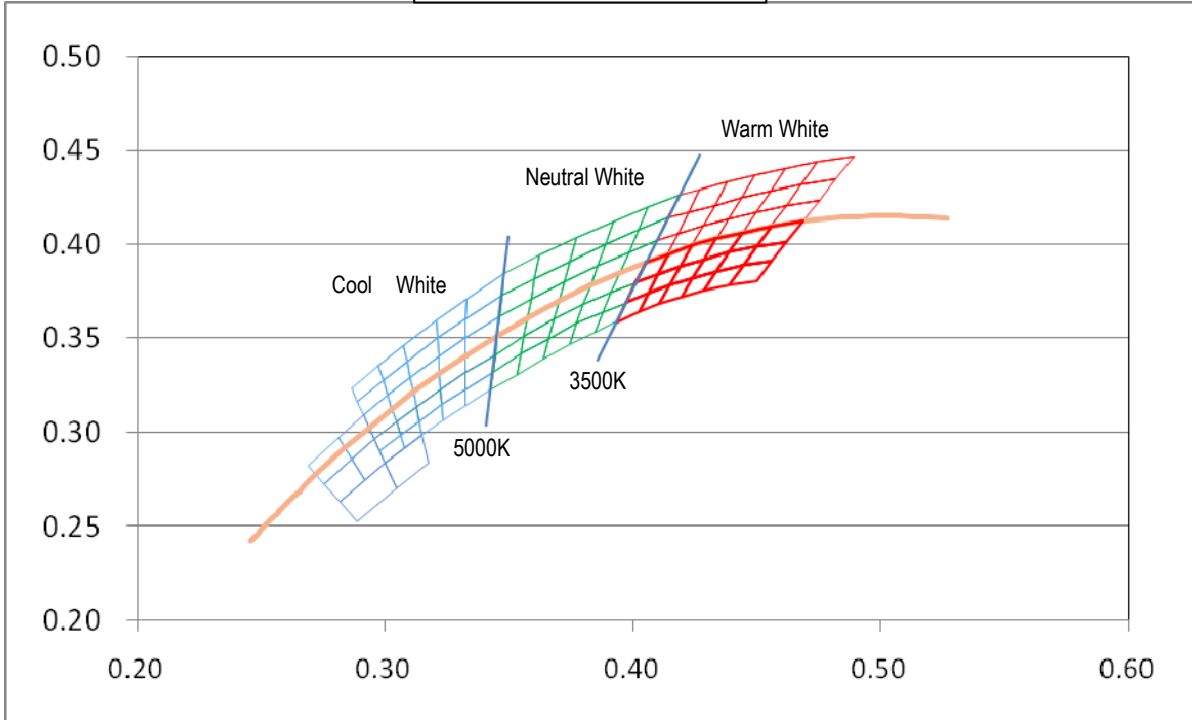

Detail Information

IM BIN Structure

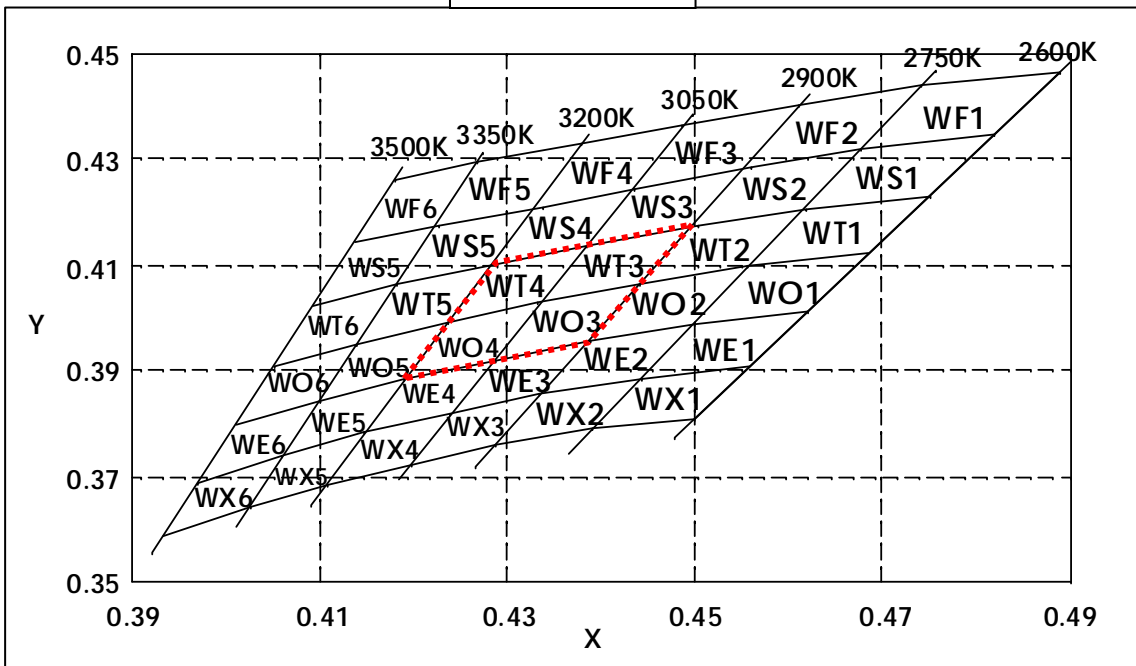

WN BIN Structure

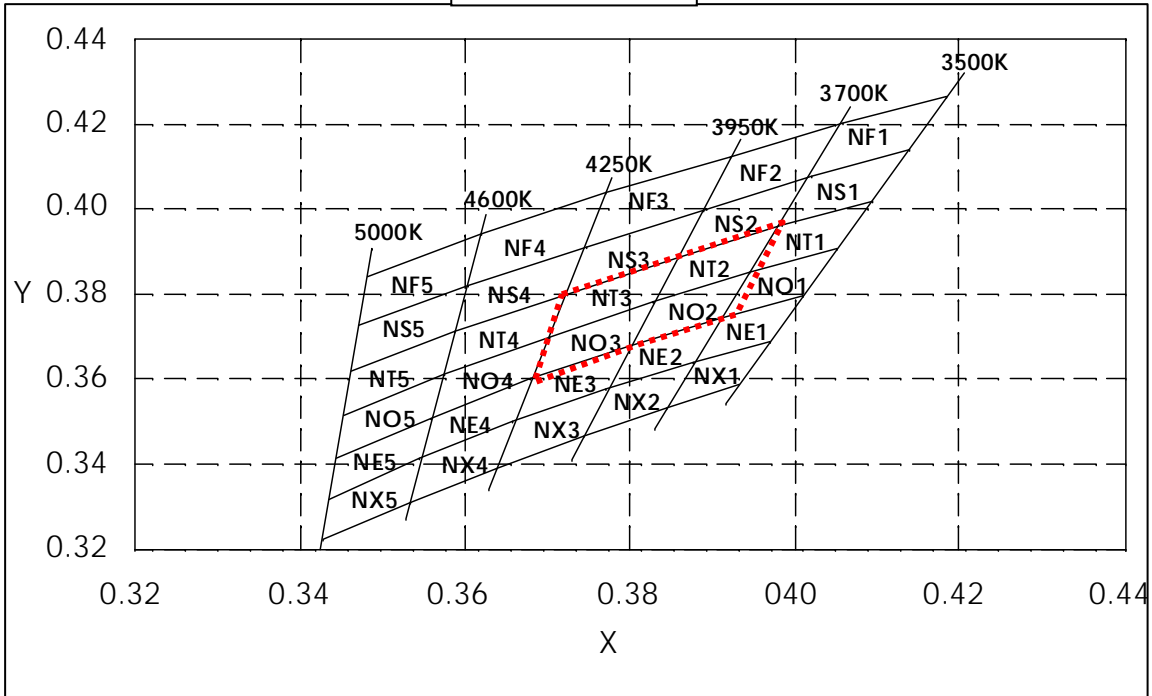

WM BIN Structure

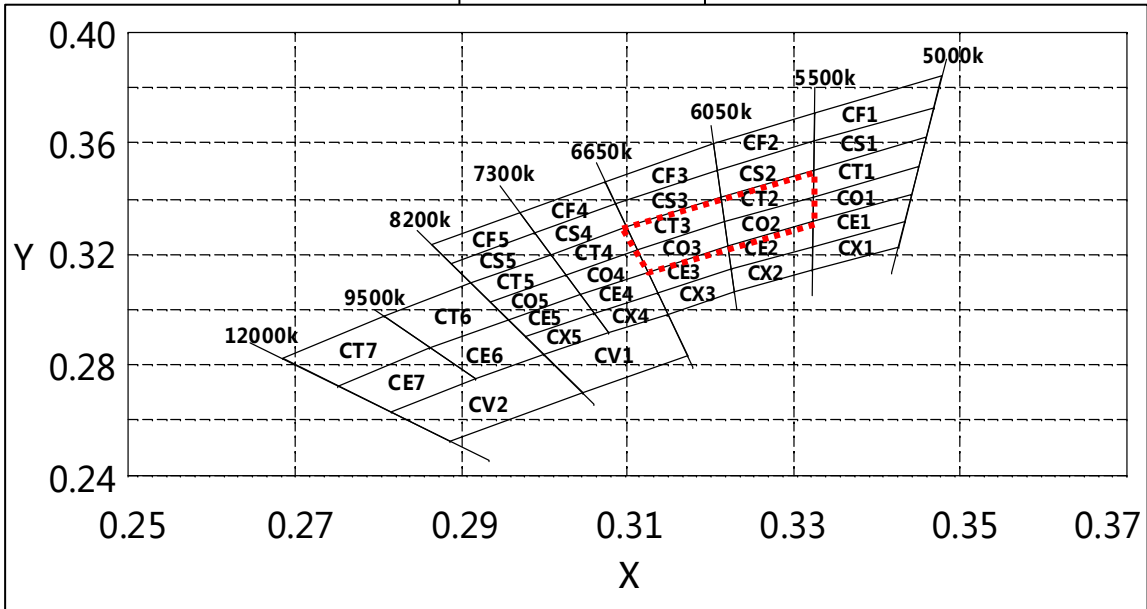

Note:  is high bin

Bin data:

BIN CODE	CIE-X1	CIE-Y1	CIE-X2	CIE-Y2	CIE-X3	CIE-Y3	CIE-X4	CIE-Y4
WF1	0.4889	0.4466	0.4742	0.4436	0.4677	0.4319	0.4817	0.4347
WF2	0.4742	0.4436	0.4613	0.4400	0.4553	0.4284	0.4677	0.4319
WF3	0.4613	0.4400	0.4489	0.4367	0.4435	0.4246	0.4553	0.4284
WF4	0.4489	0.4367	0.4380	0.4330	0.4330	0.4206	0.4435	0.4246
WF5	0.4380	0.4330	0.4267	0.4293	0.4223	0.4171	0.4330	0.4206
WF6	0.4267	0.4293	0.4184	0.4261	0.4137	0.4138	0.4223	0.4171
WS1	0.4817	0.4347	0.4677	0.4319	0.4615	0.4205	0.4749	0.4232
WS2	0.4677	0.4319	0.4553	0.4284	0.4496	0.4171	0.4615	0.4205
WS3	0.4553	0.4284	0.4435	0.4246	0.4383	0.4136	0.4496	0.4171
WS4	0.4435	0.4246	0.4330	0.4206	0.4282	0.4097	0.4383	0.4136
WS5	0.4330	0.4206	0.4223	0.4171	0.4180	0.4059	0.4282	0.4097
WS6	0.4223	0.4171	0.4137	0.4138	0.4093	0.4020	0.4180	0.4059
WT1	0.4749	0.4232	0.4615	0.4205	0.4556	0.4095	0.4682	0.4120
WT2	0.4615	0.4205	0.4496	0.4171	0.4440	0.4063	0.4556	0.4095
WT3	0.4496	0.4171	0.4383	0.4136	0.4334	0.4030	0.4440	0.4063
WT4	0.4383	0.4136	0.4282	0.4097	0.4235	0.3993	0.4334	0.4030
WT5	0.4282	0.4097	0.4180	0.4059	0.4139	0.3950	0.4235	0.3993
WT6	0.4180	0.4059	0.4093	0.4020	0.4051	0.3906	0.4139	0.3950
WO1	0.4682	0.4120	0.4556	0.4095	0.4498	0.3989	0.4618	0.4013
WO2	0.4556	0.4095	0.4440	0.4063	0.4387	0.3958	0.4498	0.3989
WO3	0.4440	0.4063	0.4334	0.4030	0.4285	0.3921	0.4387	0.3958
WO4	0.4334	0.4030	0.4235	0.3993	0.4190	0.3886	0.4285	0.3921
WO5	0.4235	0.3993	0.4139	0.3950	0.4099	0.3843	0.4190	0.3886
WO6	0.4139	0.3950	0.4051	0.3906	0.4009	0.3796	0.4099	0.3843
WE1	0.4618	0.4013	0.4498	0.3989	0.4442	0.3886	0.4555	0.3909
WE2	0.4498	0.3989	0.4387	0.3958	0.4335	0.3857	0.4442	0.3886
WE3	0.4387	0.3958	0.4285	0.3921	0.4238	0.3822	0.4335	0.3857
WE4	0.4285	0.3921	0.4190	0.3886	0.4146	0.3785	0.4238	0.3822
WE5	0.4190	0.3886	0.4099	0.3843	0.4060	0.3739	0.4146	0.3785
WE6	0.4099	0.3843	0.4009	0.3796	0.3970	0.3689	0.4060	0.3739
WX1	0.4555	0.3909	0.4442	0.3886	0.4388	0.3787	0.4495	0.3808



WX2	0.4335	0.3857	0.4285	0.3758	0.4388	0.3787	0.4442	0.3886
WX3	0.4335	0.3857	0.4238	0.3822	0.4193	0.3721	0.4285	0.3758
WX4	0.4238	0.3822	0.4146	0.3785	0.4103	0.3682	0.4193	0.3721
WX5	0.4146	0.3785	0.4060	0.3739	0.4023	0.3642	0.4103	0.3682
WX6	0.4060	0.3739	0.3970	0.3689	0.3931	0.3587	0.4023	0.3642
NF1	0.4184	0.4261	0.4058	0.4200	0.4019	0.4074	0.4137	0.4138
NF2	0.4058	0.4200	0.3920	0.4121	0.3888	0.3996	0.4019	0.4074
NF3	0.3920	0.4121	0.3770	0.4035	0.3745	0.3909	0.3888	0.3996
NF4	0.3770	0.4035	0.3618	0.3945	0.3601	0.3818	0.3745	0.3909
NF5	0.3618	0.3945	0.3479	0.3841	0.3469	0.3728	0.3601	0.3818
NS1	0.4137	0.4138	0.4019	0.4074	0.3981	0.3960	0.4093	0.4020
NS2	0.4019	0.4074	0.3888	0.3996	0.3857	0.3887	0.3981	0.3960
NS3	0.3888	0.3996	0.3745	0.3909	0.3722	0.3799	0.3857	0.3887
NS4	0.3745	0.3909	0.3601	0.3818	0.3586	0.3710	0.3722	0.3799
NS5	0.3601	0.3818	0.3469	0.3728	0.3460	0.3620	0.3586	0.3710
NT1	0.4093	0.4020	0.3981	0.3960	0.3944	0.3850	0.4051	0.3906
NT2	0.3981	0.3960	0.3857	0.3887	0.3826	0.3781	0.3944	0.3850
NT3	0.3857	0.3887	0.3722	0.3799	0.3699	0.3699	0.3826	0.3781
NT4	0.3722	0.3799	0.3586	0.3710	0.3572	0.3609	0.3699	0.3699
NT5	0.3586	0.3710	0.3460	0.3620	0.3450	0.3516	0.3572	0.3609
NO1	0.4051	0.3906	0.3944	0.3850	0.3909	0.3743	0.4009	0.3796
NO2	0.3944	0.3850	0.3826	0.3781	0.3797	0.3679	0.3909	0.3743
NO3	0.3826	0.3781	0.3699	0.3699	0.3677	0.3603	0.3797	0.3679
NO4	0.3699	0.3699	0.3572	0.3609	0.3558	0.3510	0.3677	0.3603
NO5	0.3572	0.3609	0.3450	0.3516	0.3442	0.3415	0.3558	0.3510
NE1	0.4009	0.3796	0.3909	0.3743	0.3875	0.3641	0.3970	0.3689
NE2	0.3909	0.3743	0.3797	0.3679	0.3769	0.3579	0.3875	0.3641
NE3	0.3797	0.3679	0.3677	0.3603	0.3656	0.3500	0.3769	0.3579
NE4	0.3677	0.3603	0.3558	0.3510	0.3544	0.3416	0.3656	0.3500
NE5	0.3558	0.3510	0.3442	0.3415	0.3433	0.3318	0.3544	0.3416
NX1	0.3970	0.3689	0.3875	0.3641	0.3843	0.3531	0.3931	0.3587
NX2	0.3875	0.3641	0.3769	0.3579	0.3742	0.3468	0.3843	0.3531
NX3	0.3769	0.3579	0.3656	0.3500	0.3636	0.3388	0.3742	0.3468
NX4	0.3656	0.3500	0.3544	0.3416	0.3531	0.3308	0.3636	0.3388



NX5	0.3544	0.3416	0.3433	0.3318	0.3425	0.3225	0.3531	0.3308
CZ1	0.3491	0.3978	0.3326	0.3831	0.3325	0.3706	0.3479	0.3841
CN1	0.3502	0.4106	0.3326	0.3947	0.3326	0.3831	0.3491	0.3978
CZ2	0.3326	0.3831	0.3325	0.3706	0.3204	0.3597	0.3198	0.3714
CN2	0.3326	0.3947	0.3326	0.3831	0.3198	0.3714	0.3193	0.3823
CF1	0.3479	0.3841	0.3325	0.3706	0.3324	0.3604	0.3469	0.3728
CF2	0.3325	0.3706	0.3204	0.3597	0.3208	0.3501	0.3324	0.3604
CF3	0.3204	0.3597	0.3073	0.3463	0.3087	0.3377	0.3208	0.3501
CF4	0.3073	0.3463	0.2970	0.3354	0.2989	0.3276	0.3087	0.3377
CF5	0.2970	0.3354	0.2862	0.3235	0.2887	0.3165	0.2989	0.3276
CS1	0.3469	0.3728	0.3324	0.3604	0.3324	0.3505	0.3460	0.3620
CS2	0.3324	0.3604	0.3208	0.3501	0.3213	0.3408	0.3324	0.3505
CS3	0.3208	0.3501	0.3087	0.3377	0.3100	0.3294	0.3213	0.3408
CS4	0.3087	0.3377	0.2989	0.3276	0.3008	0.3200	0.3100	0.3294
CS5	0.2989	0.3276	0.2887	0.3165	0.2910	0.3096	0.3008	0.3200
CT1	0.3460	0.3620	0.3324	0.3505	0.3323	0.3409	0.3450	0.3516
CT2	0.3324	0.3505	0.3213	0.3408	0.3217	0.3318	0.3323	0.3409
CT3	0.3213	0.3408	0.3100	0.3294	0.3112	0.3214	0.3217	0.3318
CT4	0.3100	0.3294	0.3008	0.3200	0.3025	0.3126	0.3112	0.3214
CT5	0.3008	0.3200	0.2910	0.3096	0.2933	0.3029	0.3025	0.3126
CO1	0.3450	0.3516	0.3323	0.3409	0.3322	0.3317	0.3442	0.3415
CO2	0.3323	0.3409	0.3217	0.3318	0.3221	0.3231	0.3322	0.3317
CO3	0.3217	0.3318	0.3112	0.3214	0.3124	0.3136	0.3221	0.3231
CO4	0.3112	0.3214	0.3025	0.3126	0.3043	0.3054	0.3124	0.3136
CO5	0.3025	0.3126	0.2933	0.3029	0.2955	0.2965	0.3043	0.3054
CE1	0.3442	0.3415	0.3322	0.3317	0.3322	0.3228	0.3433	0.3318
CE2	0.3322	0.3317	0.3221	0.3231	0.3225	0.3147	0.3322	0.3228
CE3	0.3221	0.3231	0.3124	0.3136	0.3136	0.3061	0.3225	0.3147
CE4	0.3124	0.3136	0.3043	0.3054	0.3059	0.2985	0.3136	0.3061
CE5	0.3043	0.3054	0.2955	0.2965	0.2977	0.2901	0.3059	0.2985
CX1	0.3433	0.3318	0.3322	0.3228	0.3321	0.3141	0.3425	0.3225
CX2	0.3322	0.3228	0.3225	0.3147	0.3229	0.3066	0.3321	0.3141
CX3	0.3225	0.3147	0.3136	0.3061	0.3148	0.2987	0.3229	0.3066
CX4	0.3136	0.3061	0.3059	0.2985	0.3076	0.2917	0.3148	0.2987



CX5	0.3059	0.2985	0.2977	0.2901	0.2998	0.2840	0.3076	0.2917
CV1	0.3148	0.2987	0.2998	0.2840	0.3045	0.2705	0.3172	0.2835
CV2	0.2998	0.2840	0.2814	0.2632	0.2886	0.2528	0.3045	0.2705
CT6	0.2910	0.3096	0.2807	0.2976	0.2863	0.2860	0.2955	0.2965
CT7	0.2807	0.2976	0.2685	0.2826	0.2751	0.2726	0.2863	0.2860
CE6	0.2955	0.2965	0.2863	0.2860	0.2916	0.2749	0.2998	0.2840
CE7	0.2863	0.2860	0.2751	0.2726	0.2814	0.2632	0.2916	0.2749
CX1	0.3433	0.3318	0.3322	0.3228	0.3321	0.3141	0.3425	0.3225
CX2	0.3322	0.3228	0.3225	0.3147	0.3229	0.3066	0.3321	0.3141
CX3	0.3225	0.3147	0.3136	0.3061	0.3148	0.2987	0.3229	0.3066
CX4	0.3136	0.3061	0.3059	0.2985	0.3076	0.2917	0.3148	0.2987
CX5	0.3059	0.2985	0.2977	0.2901	0.2998	0.2840	0.3076	0.2917
CV1	0.3148	0.2987	0.2998	0.2840	0.3045	0.2705	0.3172	0.2835
CV2	0.2998	0.2840	0.2814	0.2632	0.2886	0.2528	0.3045	0.2705
CT6	0.2910	0.3096	0.2807	0.2976	0.2863	0.2860	0.2955	0.2965
CT7	0.2807	0.2976	0.2685	0.2826	0.2751	0.2726	0.2863	0.2860
CE6	0.2955	0.2965	0.2863	0.2860	0.2916	0.2749	0.2998	0.2840
CE7	0.2863	0.2860	0.2751	0.2726	0.2814	0.2632	0.2916	0.2749

Lumilous flux(LM) BIN:

BIN CODE	MIN	MAX
Q01	60	70
Q02	70	80
Q03	80	90
Q04	90	100
Q05	100	110
Q06	110	120
Q07	120	130
Q08	130	140
Q09	140	150

VF BIN:

BIN CODE	MIN	MAX
V01	1.6	1.8
V02	1.8	2.0
V03	2.0	2.2
V04	2.2	2.4
V05	2.4	2.6
V06	2.6	2.8
V07	2.8	3.0
V08	3.0	3.2
V09	3.2	3.4
V10	3.4	3.6
V11	3.6	3.8
V12	3.8	4.0

Optical characteristics curves

Spectral Distribution

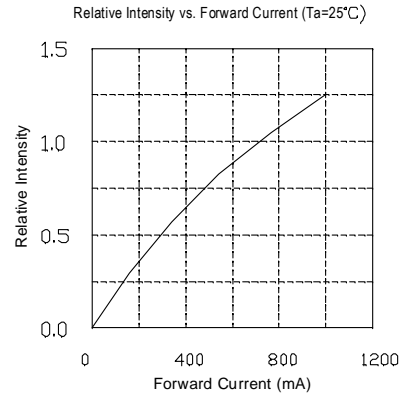
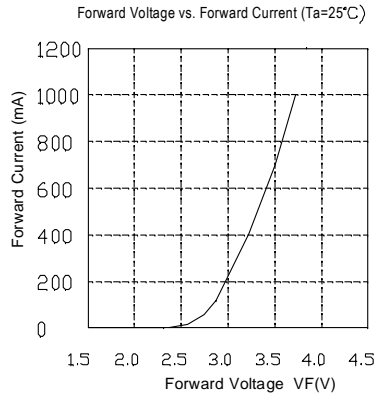
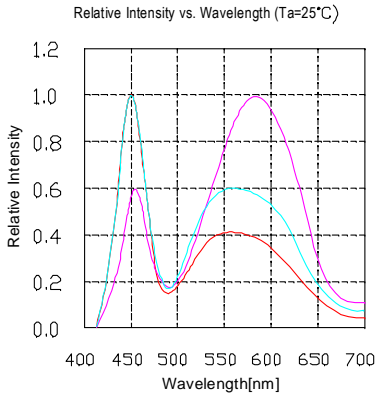

Derating

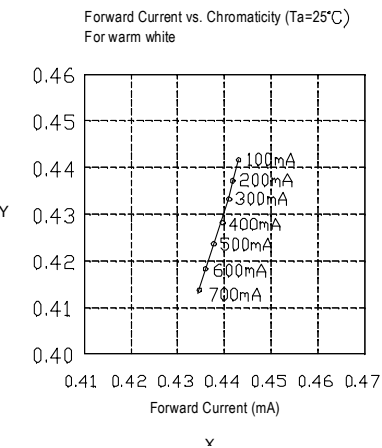
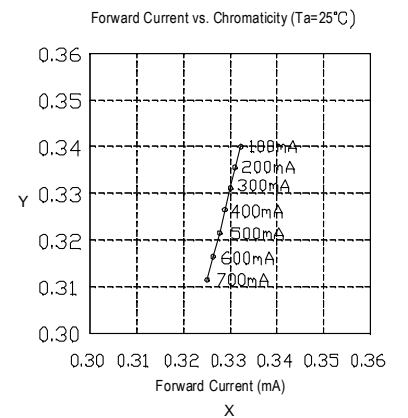
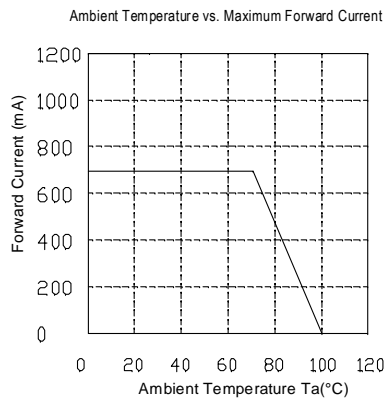
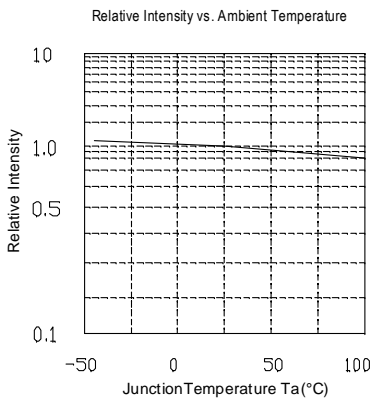
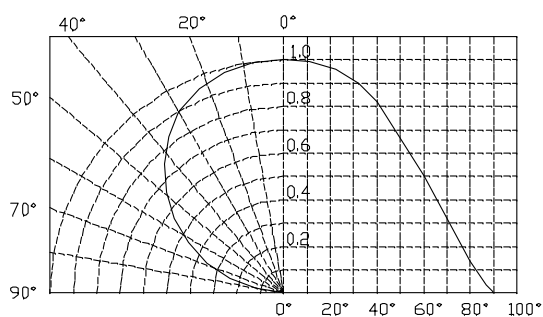

Diagram characteristics of radiation



Reflow profile

■ Soldering condition

- Recommended soldering conditions

Reflow Soldering		Hand Soldering	
Pre-heat	160~180°C	Temperature	300°C Max.
Pre-heat time	120 seconds Max.	Soldering time	3 second Max. (one time only)
Peak temperature	260°C Max.		
Soldering time	10 seconds Max.		
Condition	Refer to Temperature-profile		

- After reflow soldering rapid cooling should be avoided

■ Temperature-profile (Surface of circuit board)

Use the following conditions shown in the figure.

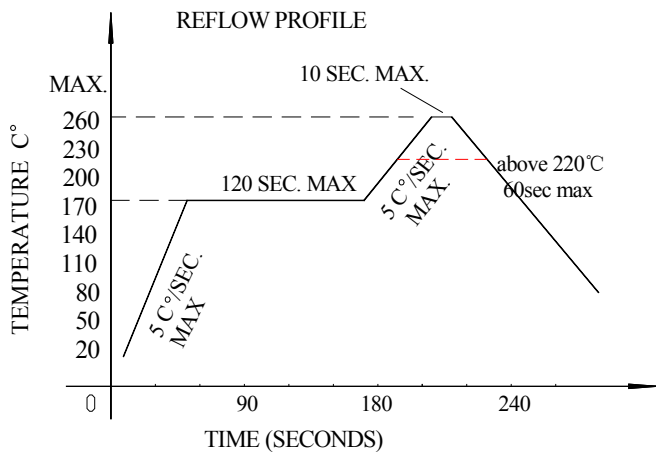

RECOMMEND PAD DESIGN (Units: mm)

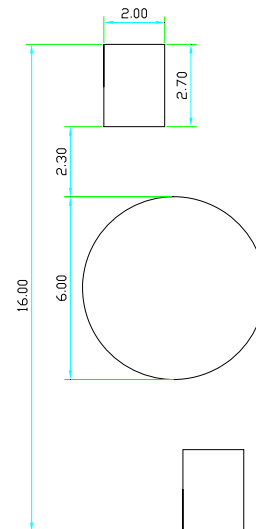

1. Reflow soldering should not be done more than two times
2. When soldering ,do not put stress on the LEDs during heating

■ Soldering iron

1. When hand soldering, keep the temperature of the iron under 300°C, and at that temperature keep the time under 3 sec.
2. The hand soldering should be done only a time
3. The basic spec is ≤ 5 sec. when the temperature of 260°C, do not contact the resin when hand soldering



Reliability

(1) TEST ITEMS AND RESULTS

Type	Test Item	Ref. Standard	Test Conditions	Note	Number of Damaged
Environmental Sequence	Resistance to Soldering Heat(Reflow Soldering)	JESD22-B106	Tsld=260°C,10sec	2 times	0/22
	Temperature Cycle	JESD22-A104	-40°C 30min ↑↓5min 100°C 30min	500 cycle	0/22
	Thermal Shock	JESD22-A106	-40°C 15min ↑↓ 100°C 15min	500 cycle	0/22
	High Temperature Storage	JESD22-A103	T _a =100°C	1000 hrs	0/22
	Low Temperature Storage	JESD22-A119	T _a =-40°C	1000 hrs	0/22
	Power temperature cycling	JESD22-A105	On 5min -40°C>15min ↑↓ ↑↓<15min Off5min 100°C>15min	100 cycle	0/22
Operation Sequence	Life Test	JESD22-A108	T _a =25°C I _F =350mA	1000 hrs	0/22
	High Humidity Heat Life Test	JESD22-A101	60°C RH=90% I _F =350mA	1000 hrs	0/22

(2) CRITERIA FOR JUDGING THE DAMAGE

Item	Symbol	Test Conditions	Criteria for Judgement	
			Min.	Max.
Forward Voltage	VF	IF=350mA	-	U.S.L*)×1.1
Reverse Current	IR	VR=5V	-	U.S.L*)×2.0
Luminous flux	Φ	IF=350mA	L.S.L**)×0.7	-

U.S.L.: Upper Standard Level

L.S.L.: Lower Standard Level



REFOND

Packaging Specifications

● Feeding Direction

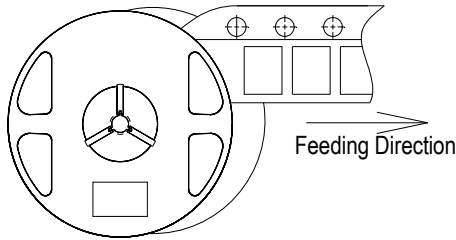

● Dimensions of Reel (Unit: mm)

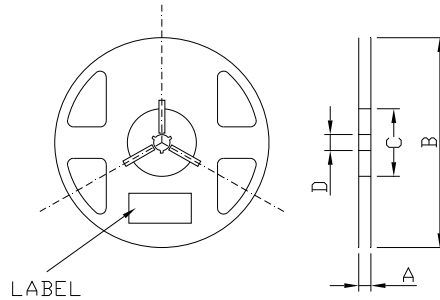

A	24.5±0.1mm
B	330±1mm
C	110±1mm
D	13.0±0.5mm

● Dimensions of Tape (Unit: mm)

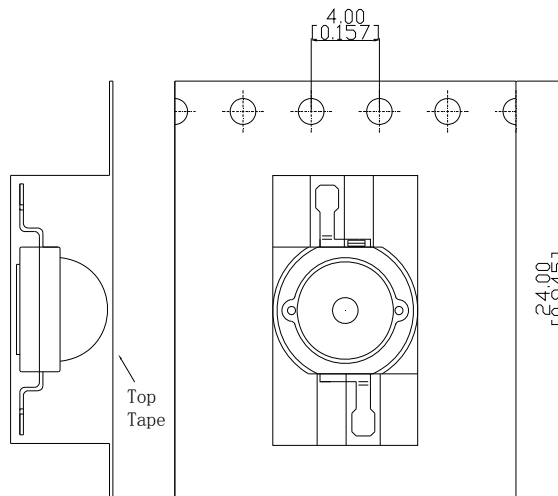

● Arrangement of Tape

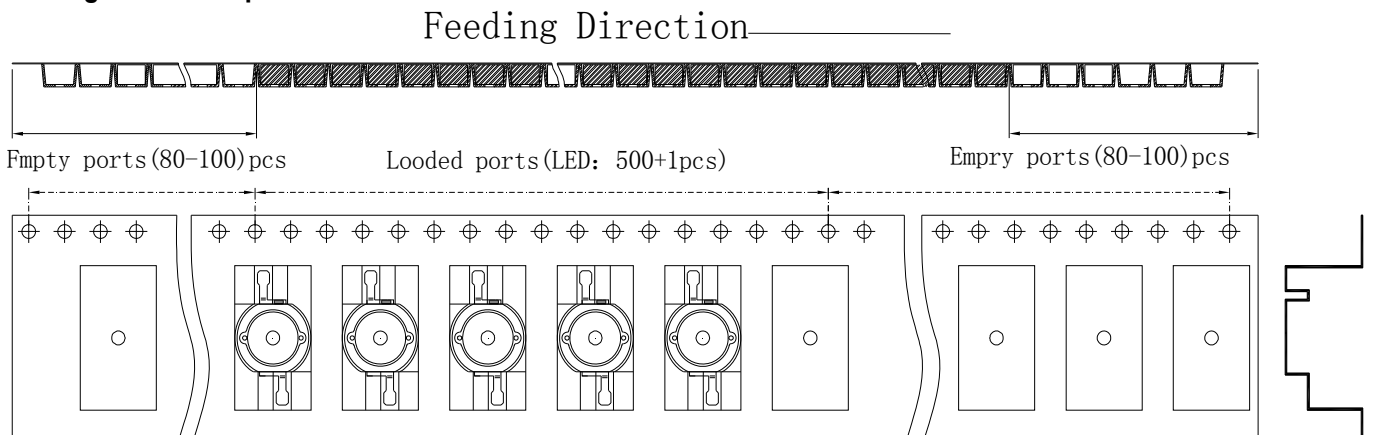

NOTES

1. Empty component pockets are sealed with top cover tape;
2. The maximum number of missing lamps is two;
3. The cathode is oriented towards the tape sprocket hole in accordance with ANSI/EIA RS-481 specifications.
4. 500 pcs/ Reel.



Packaging specifications

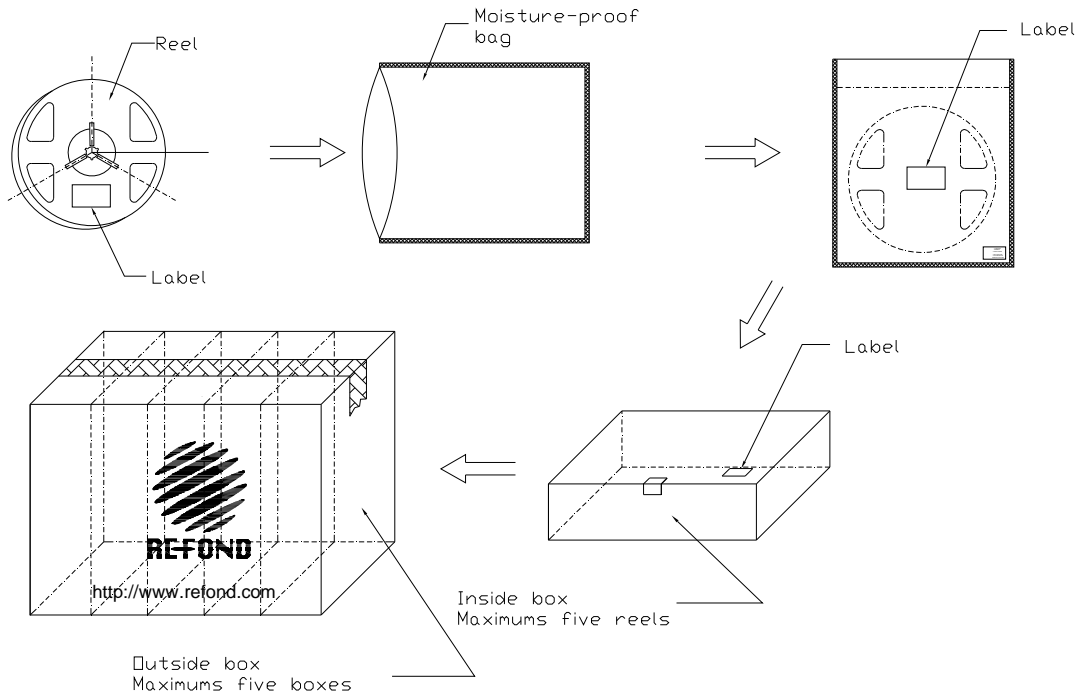

■ Label

PART NO.	
LOT NO.	
BIN CODE:	
	QTY: PCS
	DATE:

CAUTIONS

Package specifications

Reeled products (numbers of products are 500pcs) packed in a seal off moisture-proof bag along with a desiccant one by one, Five moisture-proof bag of maximums (total maximum number of products are 2,500pcs) packed in an inside box (size: about 350mm x about 350 x about 165mm), and it is packed. (Part No., Lot No., quantity should appear on the label on the moisture-proof bag, part No. And quantity should appear on the label on the cardboard box.)

Storage conditions

Before opening the package:

The LEDs should be kept at 30°C or less and 90%RH or less. The LEDs should be used within a year. When storing the LEDs, moisture proof packaging with absorbent material (silica gel) is recommended.

After opening the package:

The LEDs should be kept at 30°C or less and 70%RH or less. The LEDs should be soldered within 168 hours (7days) after opening the package. If unused LEDs remain, they should be stored in moisture proof packages, such as sealed containers with packages of moisture absorbent material (silica gel). It is also recommended to return the LEDs to the original moisture proof bag and to reseal the moisture proof bag again.