

SURFACE MOUNT RECTIFIER DIODES

GS1000FL - GS1010FL Vishaymas General Semiconductor

Features

- For surface mounted applications
- Low profile package
- Ideal for automated placement
- High temperature soldering :
260°C /10 seconds at terminals
- Glass Passivated Chip Junction

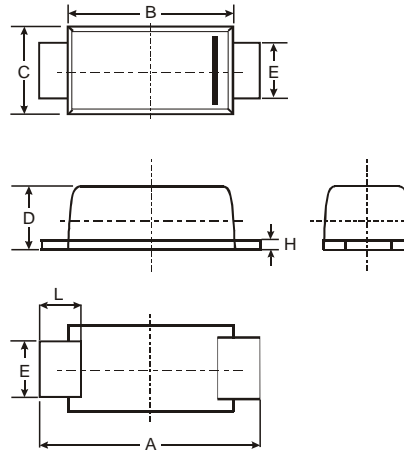

SOD-123FL			
Dim	Min	Max	Typ
A	3.58	3.72	3.65
B	2.72	2.78	2.75
C	1.77	1.83	1.80
D	1.02	1.08	1.05
E	0.097	1.03	1.00
H	0.13	0.17	0.15
L	0.53	0.57	0.55
All Dimensions in mm			

Mechanical Data

Case: JEDEC SOD-123FL molded plastic body over passivated chip

Terminals : Plated axial leads,solderable per MIL-STD-750,Method 2026

Polarity: Color band denotes cathode end

Mounting Position: Any

Weight: 0.0007 ounce, 0.02 grams

Maximum Ratings and Electrical Characteristics

TA = 25°C unless otherwise specified Single phase, half wave, 60Hz, resistive or inductive load. For capacitive load, derate current by 20%.

Characteristic	Symbol	GS1000FL	GS1002FL	GS1003FL	GS1004FL	GS1006FL	GS1008FL	GS1010FL	Unit
Maximum repetitive peak reverse voltage	V _{RRM}	50	100	200	400	600	800	1000	V
Maximum RMS voltage	V _{RMS}	35	70	140	280	420	560	700	V
Maximum DC blocking voltage	V _{DC}	50	100	200	400	600	800	1000	V
Maximum average forward rectified current at TA=65°C (NOTE 1)	I _(AV)	1.0							A
Peak forward surge current 8.3ms single half sine-wave superimposed on rated load (JEDEC Method) T _L =25°C	I _{FSM}	25.0							A
Maximum instantaneous forward voltage at 1.0A	V _F	1.1							V
Maximum DC reverse current TA=25°C at rated DC blocking voltage TA=125°C	I _R	10.0 50.0							μA
Typical junction capacitance (NOTE 2)	C _J	4							pF
Typical thermal resistance (NOTE 3)	R _{θJA}	65							K/W
Operating junction and storage temperature range	T _J ,T _{STG}	-50 to +150							°C

Note: 1. Averaged over any 20ms period.

2. Measured at 1MHz and applied reverse voltage of 4.0V D.C.

3. Thermal resistance from junction to ambient at 0.375" (9.5mm) lead length, P.C.B. mounted

Fig.1 - FORWARD CURRENT DERATING CURVE

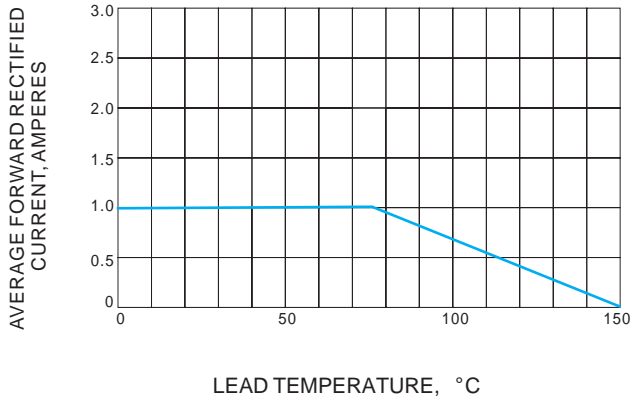

Fig.2 - TYPICAL INSTANTANEOUS FORWARD CHARACTERISTICS

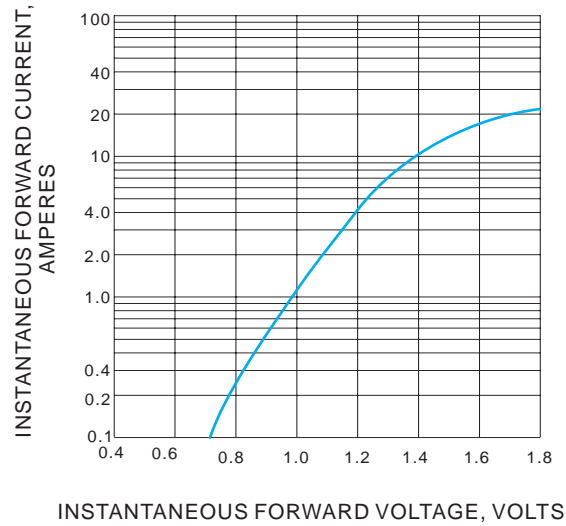

Fig.3 - TYPICAL REVERSE CHARACTERISTICS

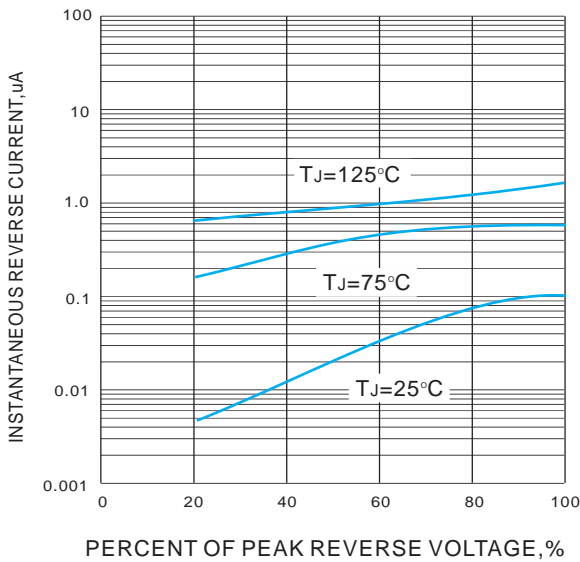

Fig.4 - TYPICAL JUNCTION CAPACITANCE

